

# TRASMAN

DESIGNED & MADE IN  
**100%**  
BARCELONA

MANUAL DE MONTAJE  
NOTICE DE MONTAGE - ASSEMBLY MANUAL  
MONTAGEANLEITUNG - MANUAL DE  
MONTAGEM - MONTAGE INSTRUCTIES  
MONTÁŽNÍ NÁVOD  
تعليمات التجميع:

## 6006 ARTIK

### V.01 - 11/22

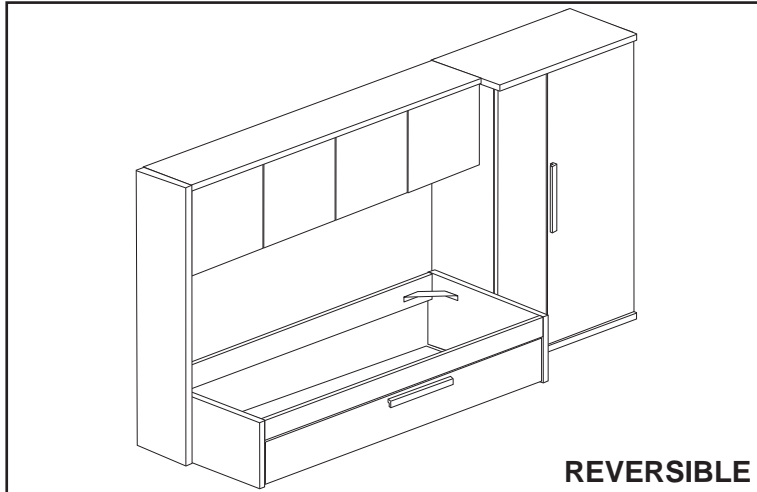

REVERSIBLE



120 min



x2

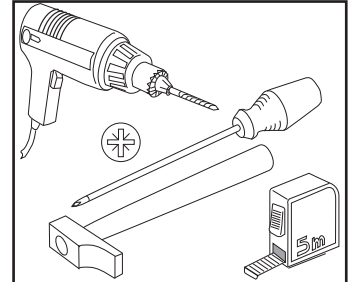

600612

600621

600615

600601

600616

600620

600631

600602

600613

600604

600605

600606

600603

600604

600601

600630

600619

600614

600617

600617

600618

600618

600622

600607

600608

600611

600611

600607

600610

ANTES DE EMPEZAR CONSULTE LOS CONSEJOS PARA EL MONTAJE.

AVANT DE COMMENCER CONSULTEZ LES INSTRUCTIONS DE MONTAGE.

BEFORE STARTING REFER TO THE ASSEMBLY ADVICE.

VOR DEM BEGINN EMPFIEHLT ES SICH AUFMERKSAM DIE HINWEISE ZUR MONTAGE ZU LESEN.

ANTES DE COMEÇAR CONSULTE OS CONSELHOS PARA A MONTAGEM.

RAADPLEEG VOORDAT U BEGINT HET MONTAGE-ADVIES.

PRED ZACÁNÍM SE PROSÍM MONTÁŽNÍ PORADENSTVÍ

اقرأ تعليمات التجميع بعناية.

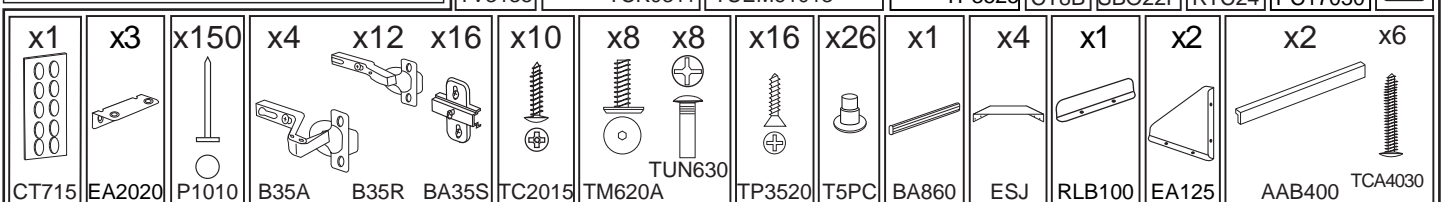
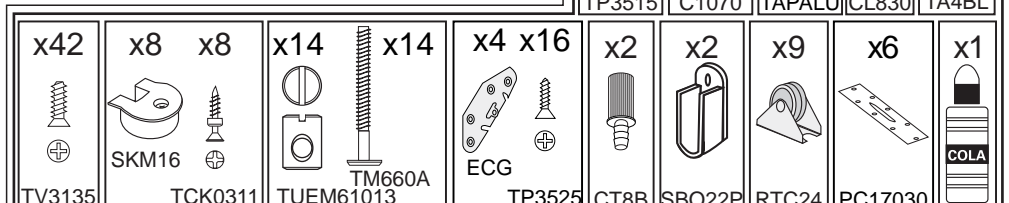
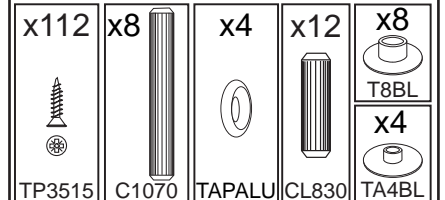
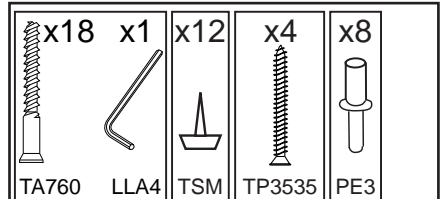

**Español (es) - Información importante sobre el montaje de los muebles en pared, leer detenidamente y guardar esta información para consultarla en el futuro.**

**ADVERTENCIA**

Una vez montado según las instrucciones de montaje, el mueble está listo para fijarlo a la pared. Pueden producirse lesiones graves o fatales si vuelca un mueble. Para evitar que vuelque este mueble, debe fijarse permanentemente a la pared. Trasman Penedès no se hace responsable de daños personales ocasionados por un montaje de pared incorrecto.

No están incluidos los tornillos para montaje en pared. Póngase en contacto con su ferretero local que le asesorará en la elección del sistema de tornillos correcto para el tipo de material de pared, dado que los diversos materiales de pared requieren diferentes tipos de herrajes de fijación.

**Français (fr) - Informations importantes concernant le montage mural de notre mobilier, a lire attentivement, conserver ces informations pour un usage ultérieur.**

**AVERTISSEMENT**

Après avoir assemblé votre meuble en suivant le mode d'emploi, vous pouvez le monter au mur. Risque de blessure grave en cas de chute du meuble. Pour éviter que le meuble ne bascule, il faut le fixer au mur de façon permanente. Trasman Penedès décline toute responsabilité en cas de blessures ou de dommages matériels dus à un montage mural incorrect.

Aucune vis n'est fournie pour le montage mural. Contactez votre quincaillier local pour sélectionner une visserie adaptée au matériau de construction de votre mur, car leur choix dépend du matériau du mur sur lequel est fixé le meuble.

**English (en) - Important information concerning wall mounting of furniture, read carefully and keep this information for further reference.**

**WARNING**

After you have assembled this product according to the assembly instructions, it can be mounted on a wall. Serious or fatal crushing injuries can occur from furniture tip-over. To prevent this furniture from tipping over it must be permanently fixed to the wall. Trasman Penedès cannot be held liable for personal or material injury as a result of incorrect mounting.

Screws for wall mounting are not included. Please contact your local specialist to ensure the correct choice of screws in relation to the wall material since different wall materials require different types of fixing devices. Use fixing devices suitable for the walls in your home.

**Deutsch (de) - Wichtige Information betr. Wandbefestigung des Schuhschranks, sorgfältig lesen, diese Information aufbewahren**

**ACHTUNG**

Beim Zusammenbau dieses Schranks müssen Sie das Möbelstück an der Wand befestigen.

Wenn Möbelstücke umkippen, können ernste oder lebensgefährliche Verletzungen durch Einklemmen die Folge sein. Um zu verhindern, dass das Möbelstück umkippt, muss es fest an der Wand verankert werden. Trasman Penedès haftet nicht für Personen- oder Sachschäden, die auf eine unsachgemäße Wandmontage zurückgeführt werden können.

Schrauben für die Wandmontage gehören nicht zum Lieferumfang. Für die korrekte Wahl eines für das jeweilige Wandmaterial geeigneten Schraubensystems wenden Sie sich bitte an den Fachhandel vor Ort, da dieses von der jeweiligen Wandbeschaffenheit abhängig ist.

**Português (pt) - Informação importante relativa a montagem na parede do móvel, ler estas instruções cuidadosamente, guardar como referência.**

**IMPORTANTE**

Depois de ter montado o móvel de acordo com as instruções de montagem, pode fixá-lo à parede. As quedas de móveis podem originar esmagamento ou morte. Estes móveis devem ser fixados à parede para evitar possíveis quedas. Trasman Penedès não se responsabiliza por ferimentos pessoais ou danos materiais ou danos como resultado da montagem incorrecta.

Os parafusos necessários para fixar o móvel à parede não estão incluídos. Por favor, contacte o seu especialista local para garantir a escolha correcta de parafusos em relação ao material, os diferentes tipos de parede requerem diferentes tipos de ferragens.

**Italiano (it) - Informazioni importanti per il fissaggio alla parete dell'armadietto per le scarpe, leggi attentamente e conserva queste informazioni per ulteriori consultazioni.**

**AVVERTENZA**

Durante il montaggio questo armadietto per le scarpe andrà fissato alla parete. Se il mobile si ribalta può causare lesioni da compressione serie o fatali. Per prevenire il rischio che il mobile si ribalti permanentemente alla parete. Trasman Penedès non potrà essere ritenuto responsabile dei danni a persone o cose dovuti ad un montaggio non corretto.

Le viti per il fissaggio a parete non sono in dotazione. Rivolgersi al locale negoziante specializzato per essere sicuri che le viti corrispondano al materiale della parete perché pareti di materiali diversi richiedono tipi diversi di accessori di fissaggio

**اللغة العربية - معلومات مهمة بخصوص التثبيت على الحائط الخاص بنا**  
الأثاث ، اقرأ بعناية ، احتفظ بهذه المعلومات لاستخدامها لاحقاً .

تحذير

بعد تجميع أثاثك باتباع تعليمات الاستخدام ، يمكنك تثبيته على الحائط. خطر الإصابة خطيرة في حال سقوط الأثاث. لمنع الخزانة من الانقلاب ، يجب تثبيتها على الحائط بشكل دائم. لا يمكن تحميل Trasman Penedès المسؤولية عن أي إصابات أو الضرر المادي بسبب التثبيت غير الصحيح على الحائط.

لا توجد براغي للتثبيت على الحائط. اتصل بمتجر الأجهزة المحلي لتحديد الأجهزة المناسبة لمواد بناء الحائط الخاص بك ، حيث يعتمد اختيارهم على مادة الحائط التي تم تركيب الأثاث عليها.

# ESPAÑOL

## CONSEJOS PARA EL MONTAJE:

- 1-ESTUDIE ATENTAMENTE EL MANUAL DE MONTAJE.
- 2-LOCALICE LAS PIEZAS QUE CONSTITUYEN SU MUEBLE.
- 3-REUNA Y CONTROLE LOS HERRAJES SUMINISTRADOS.
- 4-EQUIPESE CON LAS HERRAMIENTAS NECESARIAS.
- 5-PREPARE UNA ZONA DE MONTAJE.

## CONSEJOS PARA EL MANTENIMIENTO:

- 1-QUITAR EL POLVO CUIDADOSAMENTE.
- 2-HUMEDECER UN PAÑO SUAVE Y LIMPIO CON AGUA LIGERAMENTE ENJABONADA.

NO FUERCE NUNCA EN LAS UNIONES APRIETE LOS TORNILLOS DESPUES DE CIERTO TIEMPO DE UTILIZACION. CONSERVE SU MANUAL DE MONTAJE. SI FALTARA UNA PIEZA SERIA LA MANERA MAS FACIL DE COMUNICARLO A LA TIENDA.

NO USE NUNCA PRODUCTOS ABRASIVOS TALES COMO: LANA DE ACERO , LIJAS,DISOLVENTES,ETC. NO MOJAR NI SOMETER A GRANDES HUMEDADES AL MUEBLE.

# FRANCAIS

## INSTRUCTIONS DE MONTAGE:

- 1-LISEZ ATTENTIVEMENT LA NOTICE DE MONTAGE.
- 2-REPEREZ LES PIECES QUI COMPOSENT VOTRE MEUBLE.
- 3-REGROUPEZ ET VERIFIEZ LES FERRURES FOURNIES.
- 4-DOTEZ-VOUS DES OUTILS NECESSAIRES.
- 5-PREPAREZ UN ESPACE DE MONTAGE.

## CONSEILS D'ENTRETIEN:

- 1-ENLEVEZ SOIGNEUSEMENT LA POUSSIERE.
- 2-HUMIDIFIEZ UN CHIFFON DOUX ET PROPRE AVEC DE L'EAU LEGEREMENT SAVONNEUSE.

LES MEUBLES CONTENANT DES PANNEAUX À BASE DE BOIS (PANNEAUX DE PARTICULES, PANNEAUX DE FIBRES, CONTREPLAQUÉ...) PEUVENT ÉMETTRE DES SUBSTANCES POLLUANTES DANS L'AIR INTÉRIEUR. IL EST AINSI RECOMMANDÉ, APRÈS L'INSTALLATION DU MEUBLE DANS SON LOGEMENT, D'AÉRER FRÉQUEMMENT LA PIÈCE CONCERNÉE PENDANT AU MOINS QUATRE SEMAINES AFIN DE RÉDUIRE SON EXPOSITION AUX POLLUANTS ÉMIS PAR LE MEUBLE.

NE FORCEZ JAMAIS LES RACCORDS. RESSERREZ LES VIS APRES UN CERTAIN TEMPS D'UTILISATION. CONSERVEZ LA NOTICE DE MONTAGE. EN CAS DE PIECE MANQUANTE , CE SERA LE MEILLEUR MOYEN D'EN INFORMER LE MAGASIN.

N'UTILISEZ JAMAIS DES PRODUITS ABRASIFS COMME DE LA LAINE D'ACIER, DU PAPIER DE VERRE, DES SOLVANTS, ETC. NE MOUILLEZ PAS LE MEUBLE ET EVITEZ TOUTE ESPOSITION A UNE HUMIDITE IMPORTANTE.

# ENGLISH

## ASSEMBLY ADVICE:

- 1- STUDY THE ASSEMBLY MANUAL CAREFULLY.
- 2- LOCATE THE PARTS THAT COMPRISE YOUR FURNITURE ITEM.
- 3- ORGANISE AND CHECK THE FITTINGS SUPPLIED.
- 4- HAVE THE NECESSARY TOOLS TO HAND.
- 5- PREPARE AN ASSEMBLY AREA.

## MAINTENANCE ADVICE:

- 1- REMOVE DUST CAREFULLY.
- 2- MOISTEN A SOFT, CLEAN CLOTH WITH SLIGHTLY SOAPY WATER.

DO NOT FORCE ANY OF THE JOINTS. TIGHTEN THE SCREWS AFTER HAVING USED THE FURNITURE FOR SOME TIME. KEEP YOUR ASSEMBLY MANUAL. IF ANY PART IS MISSING, IT WILL HELP YOU TO LET THE SHOP KNOW.

NEVER USE ABRASIVE PRODUCTS SUCH AS STEEL WOOL, SANDPAPER, ETC. DO NOT WET THE FURNITURE OR KEEP IT IN A VERY DAMP PLACE.

# DEUTSCH

## HINWEISE ZUR MONTAGE:

- 1- LESEN SIE AUFMERKSAM DIE MONTAGEANLEITUNG DURCH.
- 2- LOKALISIEREN SIE DIE ZUM MÖBEL GEHÖRENDE TEILE.
- 3- KONTROLLIEREN SIE DIE MITGELIEFERTEN WERKZEUGE.
- 4- RÜSTEN SIE SICH MIT DEN ZUSÄTZLICH BENÖTIGTEN WERKZEUGEN AUS.
- 5- BEREITEN SIE EINEN PLATZ FÜR DIE MONTAGE VOR.

## HINWEISE ZUR PFLEGE:

- 1- ENTFERNEN SIE UMSICHTIG DEN ANGESAMMELTEN STAUB.
- 2- VERWENDEN SIE EIN WEICHES UND SAUBERES TUCH UND SCHWACHE SEIFENLAUGE.

FORCIEREN SIE NIEMALS DIE VERBINDUNGEN. ZIEHEN SIE DIE SCHRAUBEN NACH EINER BESTIMMTEN NUTZUNGSZEIT NACH. BEWAHREN SIE DIE MONTAGEANLEITUNG AUF. SOLLTE EIN TEIL FEHLEN IST SIE VON GROSSER WICHTIGKEIT BEI DER NACHBESTELLUNG IM LADEN.

VERWENDEN SIE NIEMALS SCHEUERENDE PRODUKTE WIE STAHLWOLLE, SCHMIRGELPAPIER, LÖSUNGSMITTEL UND DERGL. WASSER UND HOHE FEUCHTIGKEIT SIND SCHÄDLICH FÜR DAS MÖBEL.

# POTUGUES

## CONSELHO PARA A MONTAGEM :

- 1 - ESTUDE ATENTAMENTE O MANUAL DE MONTAGEM.
- 2 - LOCALIZE AS PEÇAS QUE CONSTITUEM O SEU MÓVEL.
- 3 - REUNA E CONTROLE AS FERRAGENS FORNECIDAS.
- 4 - EQUIPE-SE COM AS FERRAMENTAS NECESSÁRIAS.
- 5 - PREPARE UMA ZONA DE MONTAGEM.

## CONSELHOS PARA A MANUTENÇÃO :

- 1- RETIRAR A POEIRA COM CUIDADO.
- 2- HUMEDECER UM PANO SUAVE E LIMPO COM ÁGUA LIGEIRAMENTE ENSABOADA.

NUNCA FORCE AS UNIÕES. APORTE OS PARAFUSOS DEPOIS DE DETERMINADO TEMPO DE UTILIZAÇÃO.. CONSERVE O SEU MANUAL DE MONTAGEM, SE FALTAR UMA PEÇA SERIA A MANEIRA MAIS FÁCIL DE A COMUNICAR À LOJA.

NUNCA USE PRODUTOS ABRASIVOS TAIS COMO : LÃ DE AÇO, LIXAS, DISSOLVENTS, ETC.. NÃO MOLAR NEM SUBMETTER A GRANDES HUMIDADES, O MÓVEL.

# ITALIANO

## CONSIGLI PER IL MONTAGGIO:

- 1- STUDIARE ATTENTAMENTE IL MANUALE DI MONTAGGIO.
- 2- INDIVIDUARE LE PARTI CHE COSTITUISCONO IL MOBILE.
- 3- RACCOGLIERE E CONTROLLARE GLI ATTREZZI IN DOTAZIONE.
- 4- PROCURARSI GLI ATTREZZI NECESSARI.
- 5- PREPARARE UNA ZONA PER IL MONTAGGIO.

## CONSIGLI PER LA MANUTENZIONE:

- 1- SPOLVERARE ACCURATAMENTE.
- 2- INUMIDIRE UN PANNINO MORBIDO E PULITO CON ACQUA E POCO DETERGENTE.

NON FORZARE MAI LE GIUNTURE. STRINGERE NUOVAMENTE LE VITI DOPO UN CERTO PERIODO D'USO. CONSERVARE IL MANUALE DI MONTAGGIO: SE MANCASSE UN PEZZO SAREBBE COSÌ PIÙ FACILE COMUNICARLO AL RIVENDITORE.

NON USARE MAI PRODOTTI ABRASIVI COME: SPUGNE ABRASIVE, CARTA VETRATA, SOLVENTI, ECC. NON BAGNARE NE' SOTTOPORRE IL MOBILE A FORTE UMIDITÀ.

# اللغة العربية

## تعليمات التجميع:

- 1-اقرأ تعليمات التجميع بعناية.
- 2-حدد موقع الأجزاء التي يتكون منها أثاثك.
- 3-الجمع والتحقق من الأجهزة المقدمة.
- 4-هل لديك الأدوات اللازمة.
- 5-جهز مساحة التركيب.

## إرشادات الصيانة:

- 1-قم بإزالة الغبار بعناية.
- 2-قم بتربيط قطعة قماش ناعمة ونظيفة بالصابون الخفيف والماء.

لا تفرض التركيبات أبداً. شد البراغي بعد وقت معين من الاستخدام. احفظ تعليمات التجميع. في حالة وجود جزء مفقود ، ستكون هذه أفضل طريقة لإعلام المتجر.

لا تستخدم أبداً المنتجات الكاشطة مثل الصوف الصلب ، ورق الرمل ، والمذيبات ، وما إلى ذلك. لا تبلل الأثاث وتجنب أي تعرض للرطوبة العالية.

HERRAJES

FERRURES

MÖBELBESCHLÄGE

ACCESSORI  
PER MOBILI

FERRAGENS

OKUCIA  
MEBLOWE

FURNITURE  
FITTINGS

T1

x18

x1

x12

x4

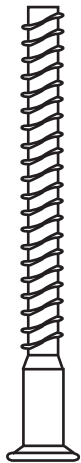

TA760



LLA4

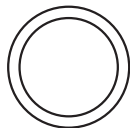

TSM



TP3535

T2

x8

x112

x8



PE3



TP3515



CL1070

T3

x12

x4

x8

x42



CL830



TA4BL



T8BL



TV3135

T4

x8

x8

x14

x14

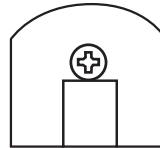
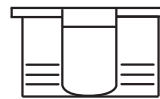

SKM16



TCK0311

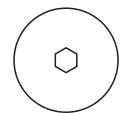
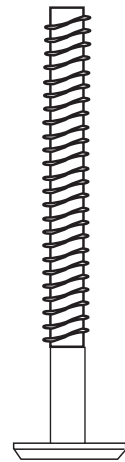

TCK0311



TUEM61013

T5

x16

x4

x2

x2



TP3525



TAPALU

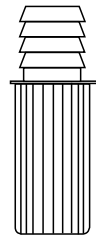

CT8B



SBO22P

HERRAJES

FERRURES

MÖBELBESCHLÄGE

ACCESSORI  
PER MOBILI

FERRAGENS

OKUCIA  
MEBLOWE

FURNITURE  
FITTINGS

W



x9



RTC24

x1

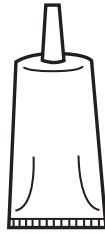

COLA

x1

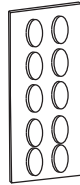

CT715

x3

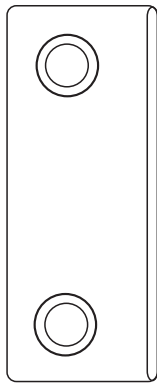

EA2020

x5



P1010

x4

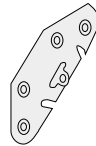

ECG

X



x6

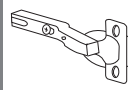

B35R

x6



BA35S

V



x6

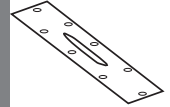

PC17030

T6



x10



TC2015

x8

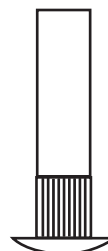

TUN630

x8



TM620A

x16



TP3520

Y



x6

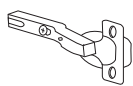

B35R

x6



BA35S

Z



x4

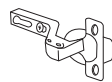

B35A

x4



BA35S

T7



x26



T5PC

AC



x1



BA860

x4

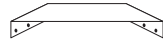

ESJ

x1



RLB100

x2

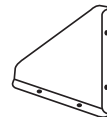

EA125

x2



AAB400

1/7

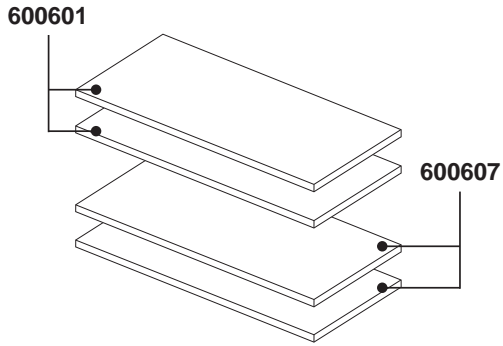

6006A

2/7

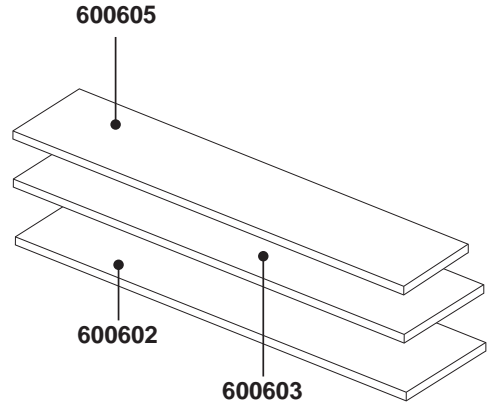

6006B

3/7

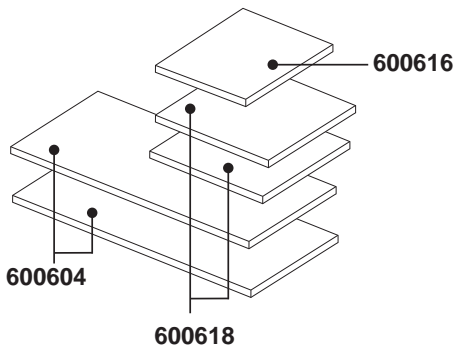

T1 T2  
T3 T4  
T5 T6  
V W  
X Y  
Z AC

6006C

4/7

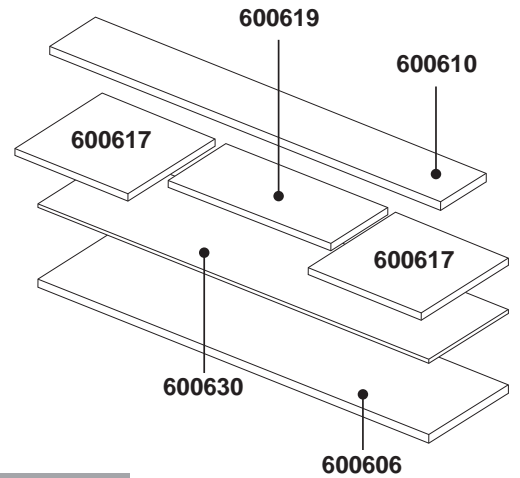

T7

6006D

5/7

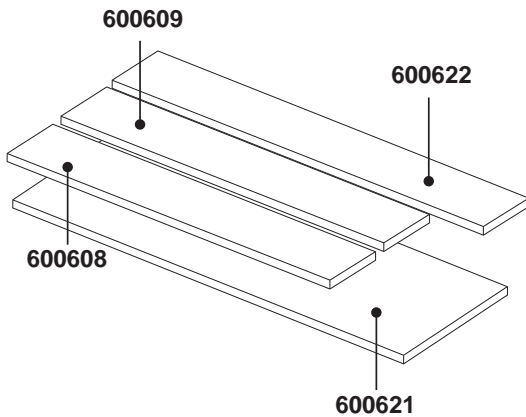

6006E

6/7

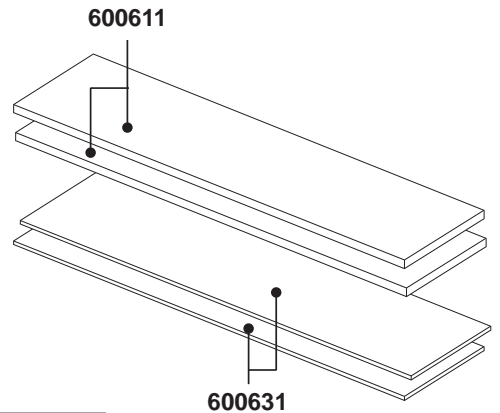

6006F

7/7

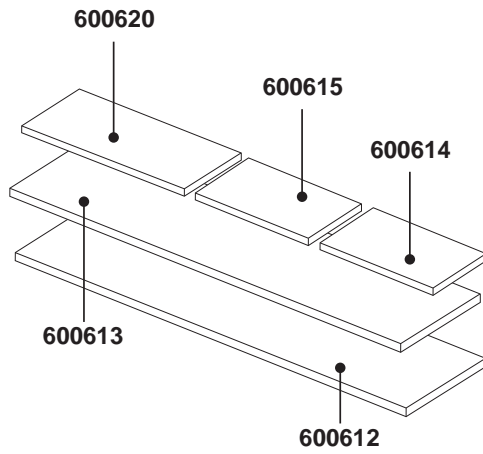



6006G

cm 0 1 2 3 4 5 6 7

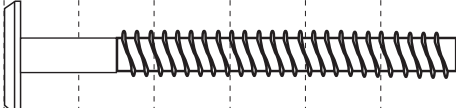
C1070   x8

TM660A   x2

TA760   x2

cm 0 1 2

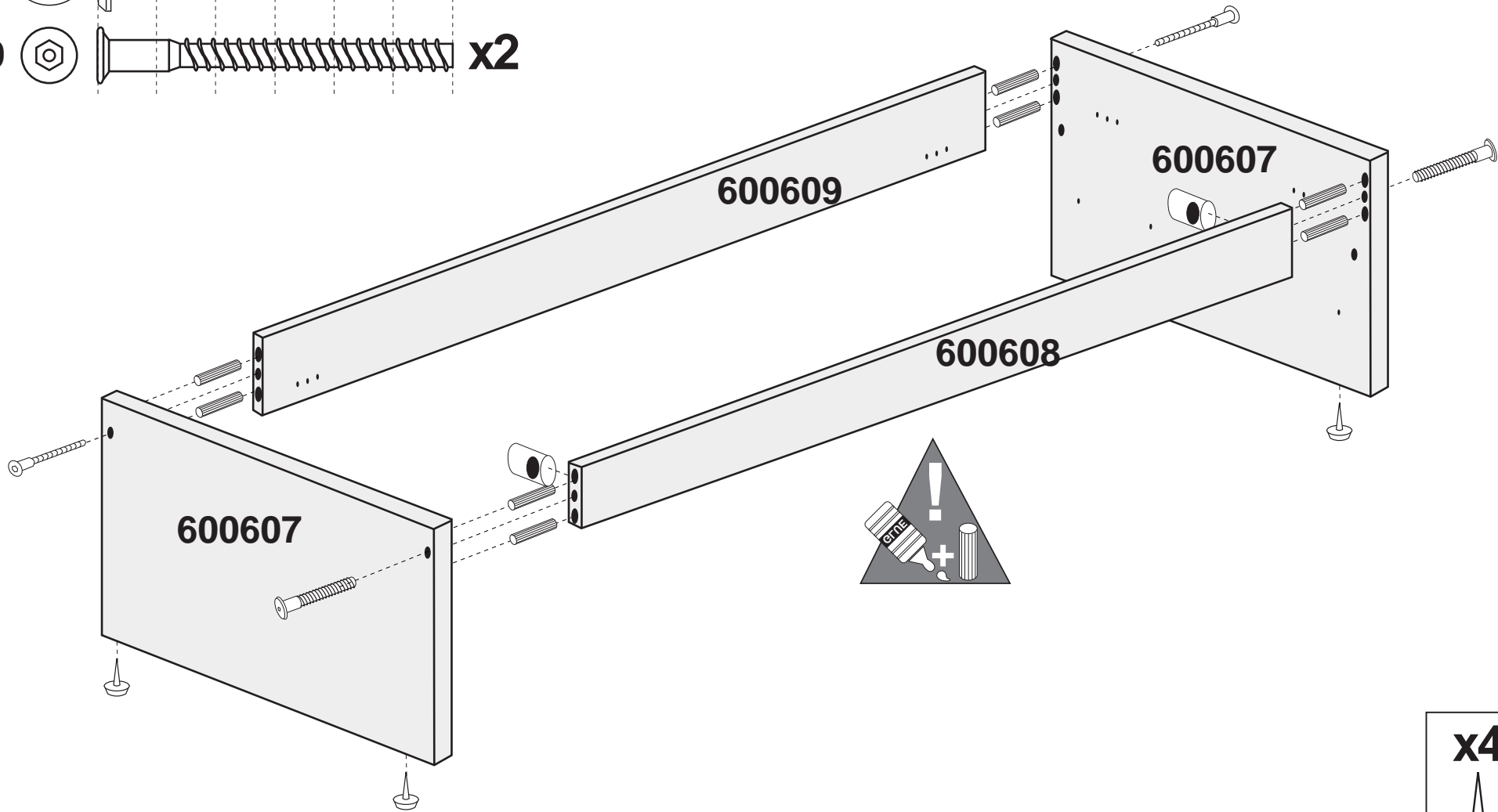

TUEM61013   x2



x4  
  
TSM

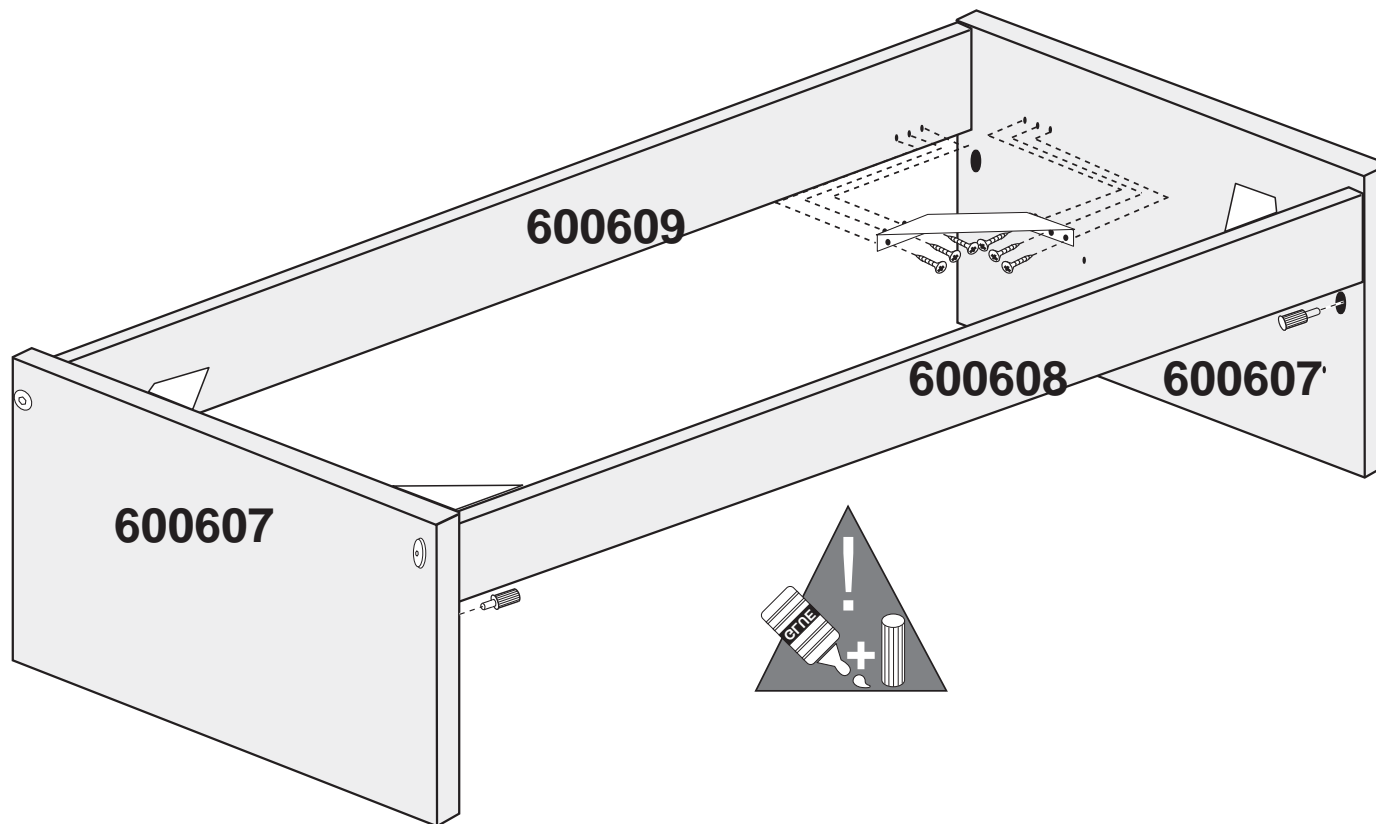



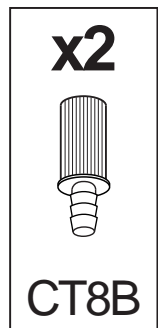
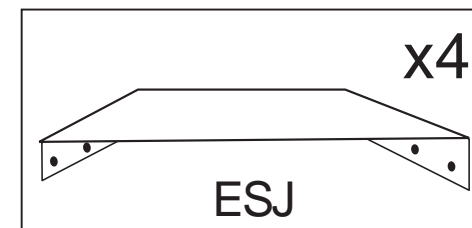

cm 0 1 2  
TP3515   **x24**

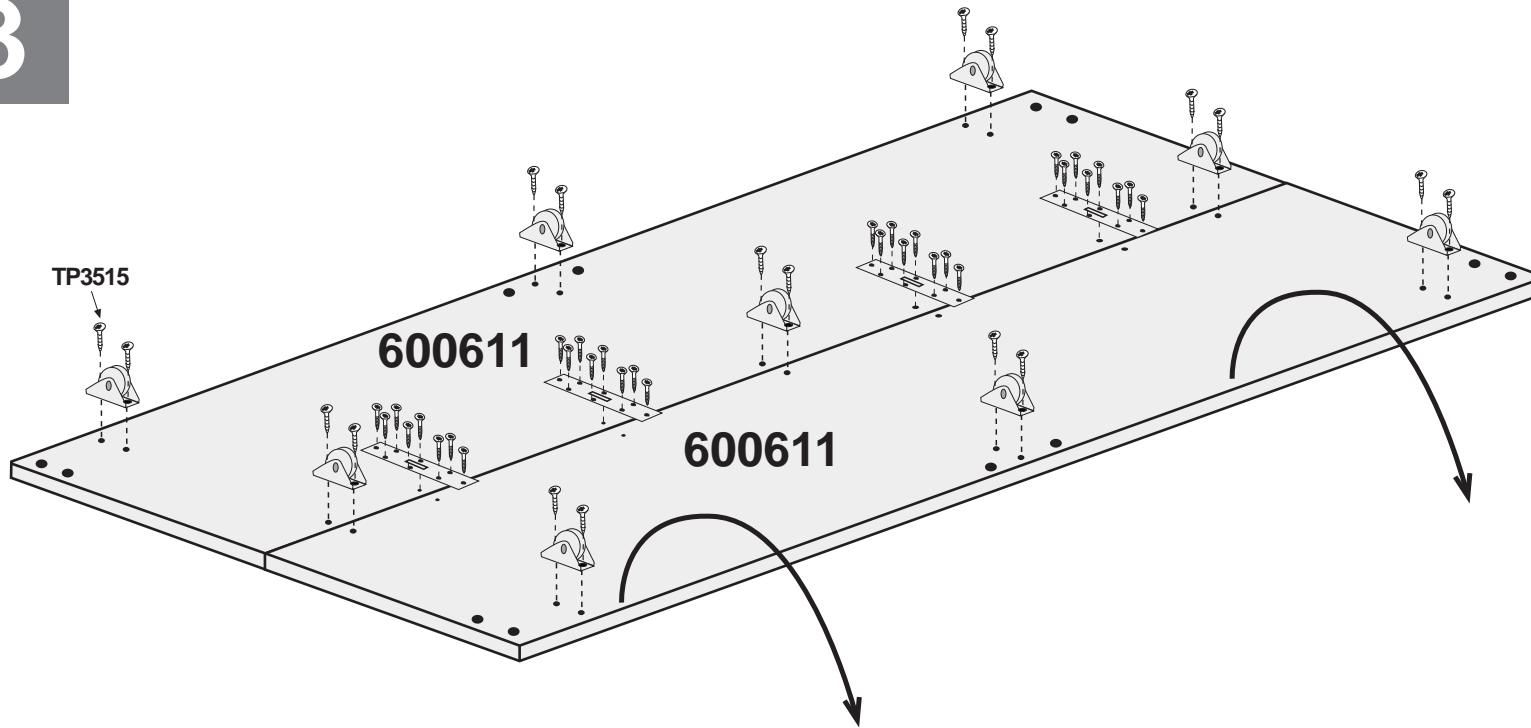

3



x9



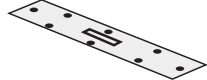

RTC24

x4



PC17030

cm 0 1 2

TP3515   x50

4

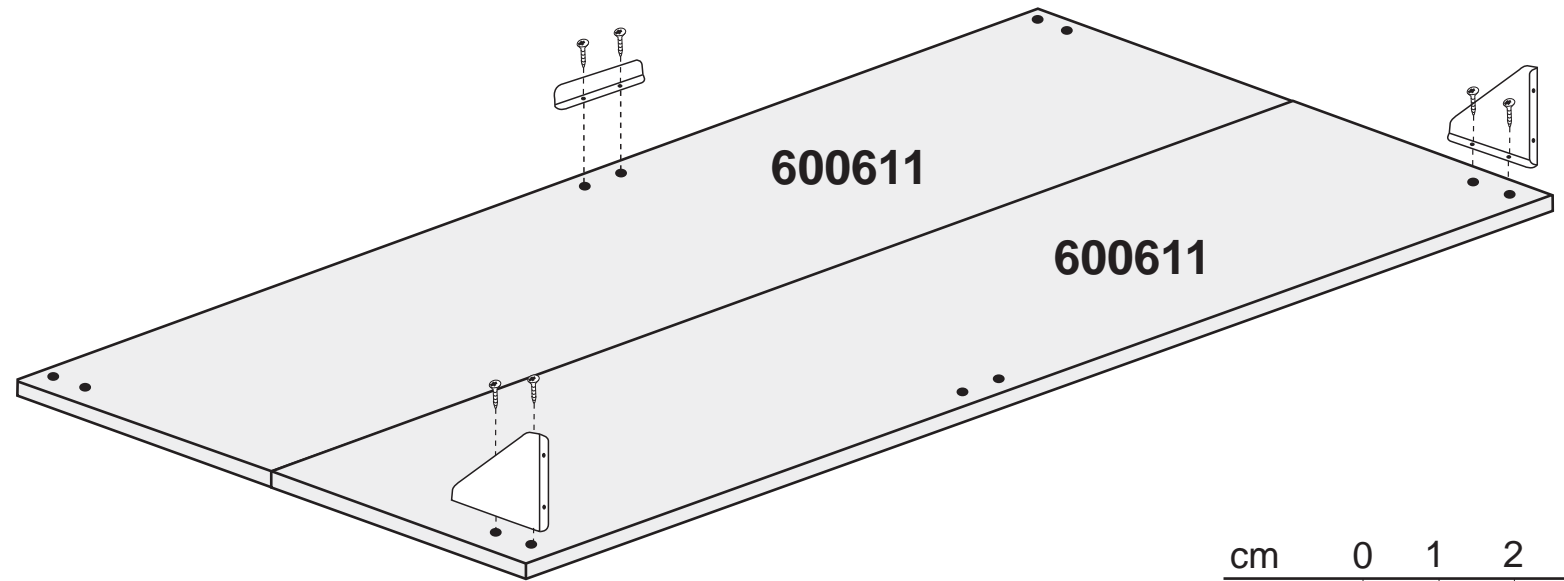

x2

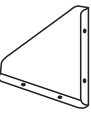

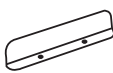

EA125

x1



RLB100

cm 0 1 2

TC2015   x6

5

x14



T5PC

600611

600610

TP3515

TV3135

TC2015

cm 0 1 2

TV3135 x2

TP3515 x2

TC2015 x4

∅ 5 mm

600610

x1

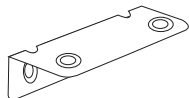

EA2020

x1

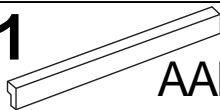

AAB400

x3

TCA4030

x8

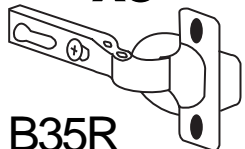

B35R

600605

600606

cm 0 1 2

TP3515 x16

∅ 5 mm

600606

6

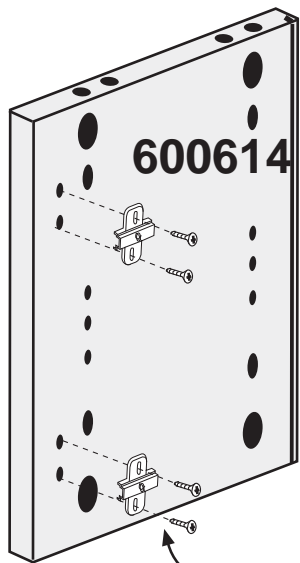

600614

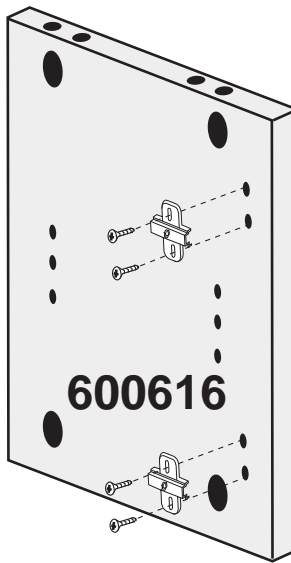

600616

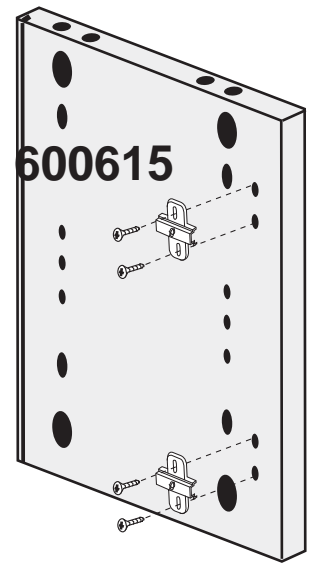

600615

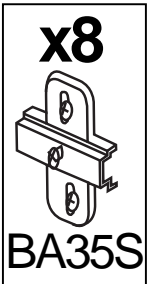

x8

BA35S

cm 0 1 2

TV3135   x16

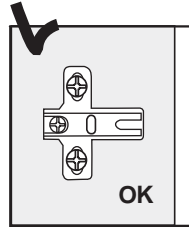

OK

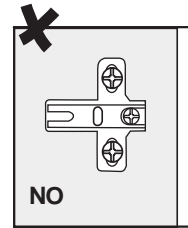

NO



7

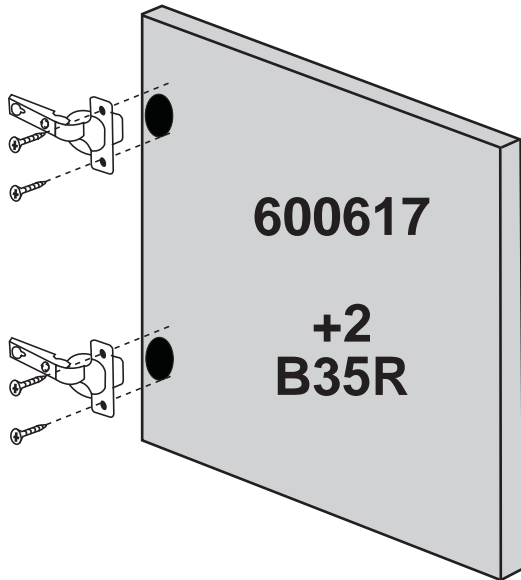

600617

+2  
B35R

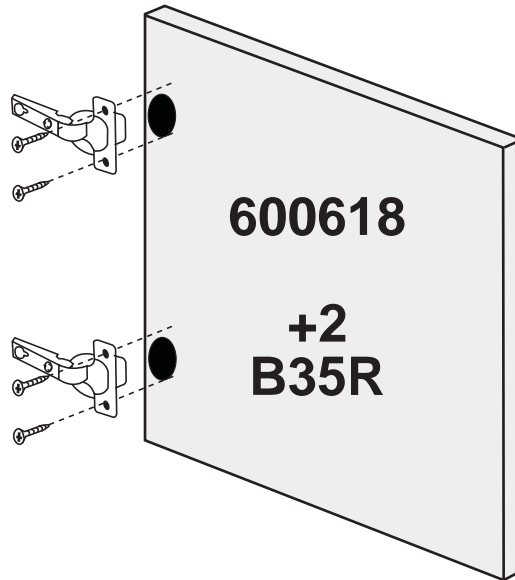

600618

+2  
B35R

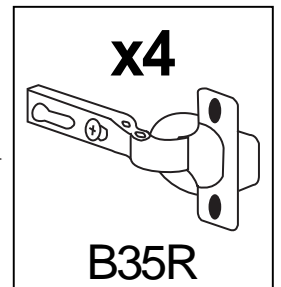

x4

B35R

cm 0 1 2

TP3515   x16

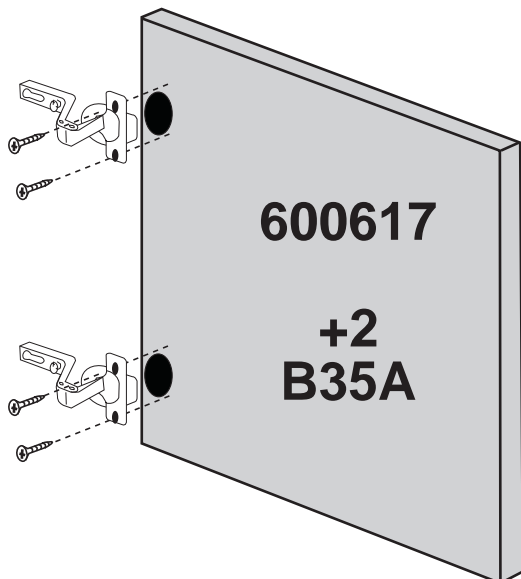

600617

+2  
B35A

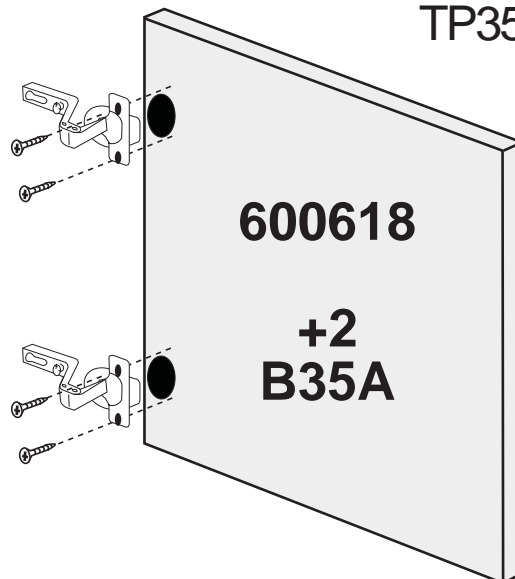

600618

+2  
B35A

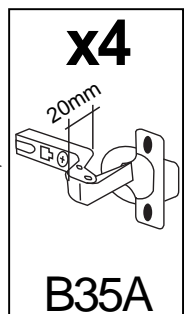

x4

B35A

8

cm 0 1 2 3 4 5 6



TM660A  **x6**

CL830  **x6**

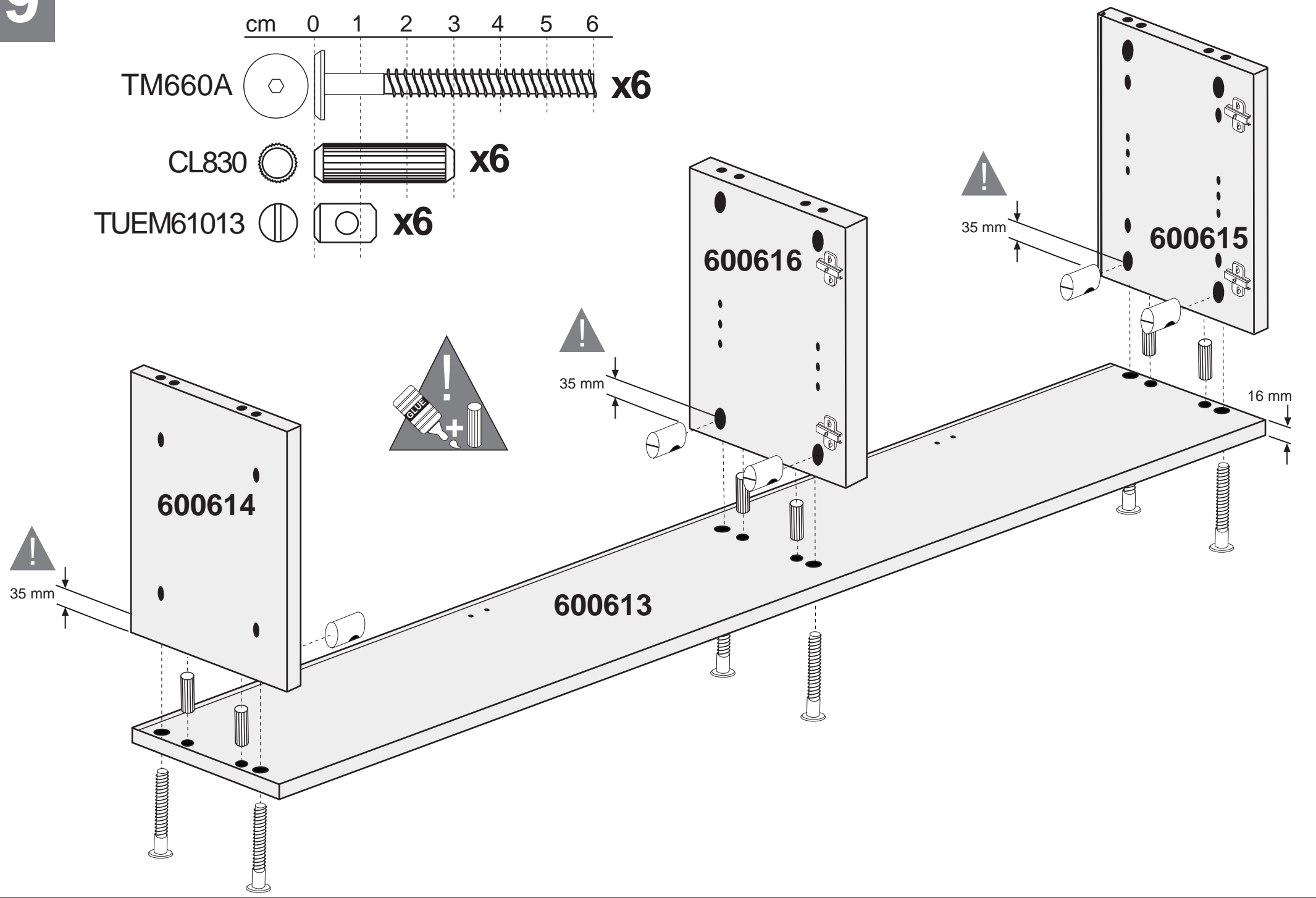
TUEM61013  **x6**



cm 0 1 2 3 4 5 6

TM660A   **x6**

CL830   **x6**

TUEM61013   **x6**

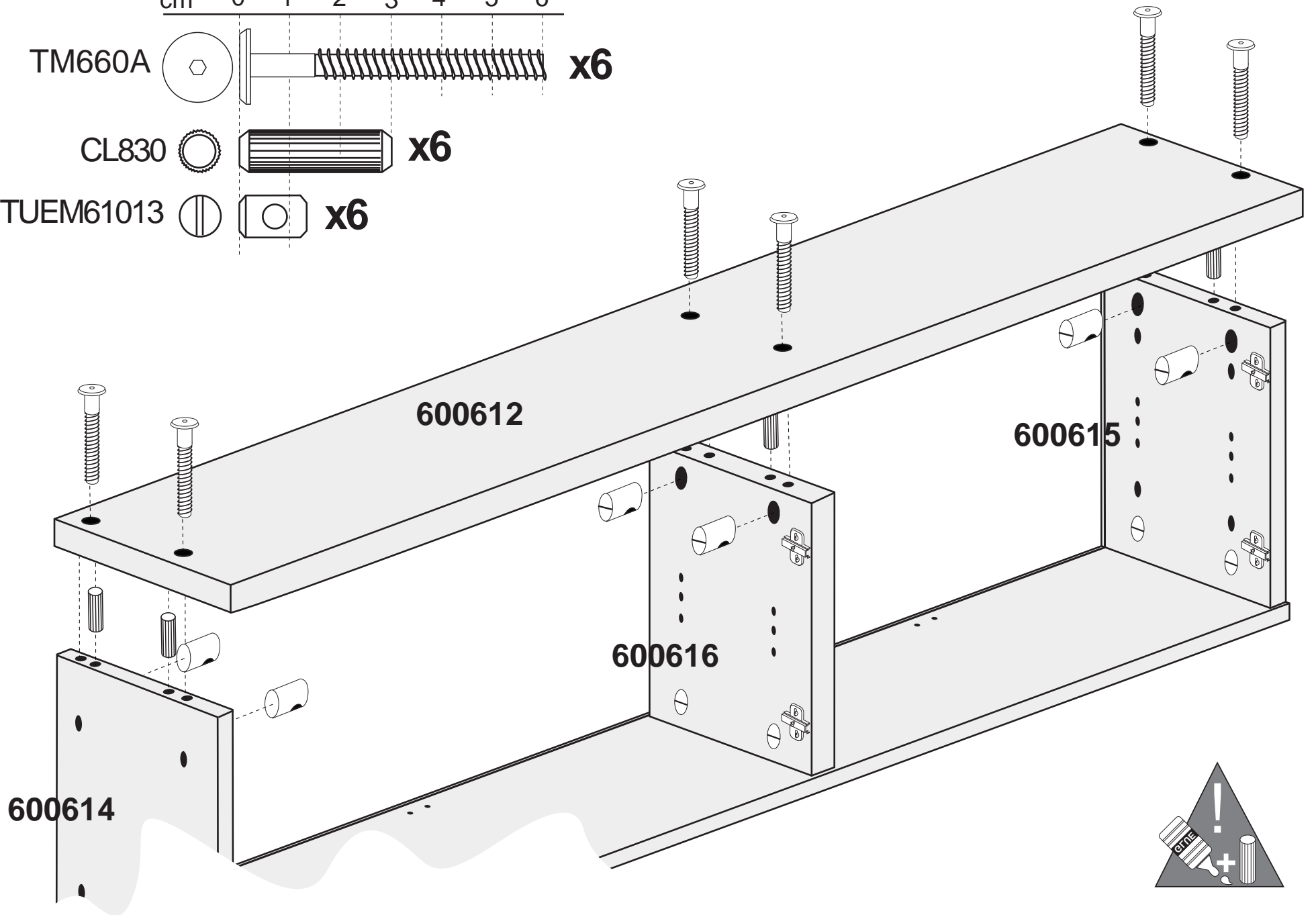

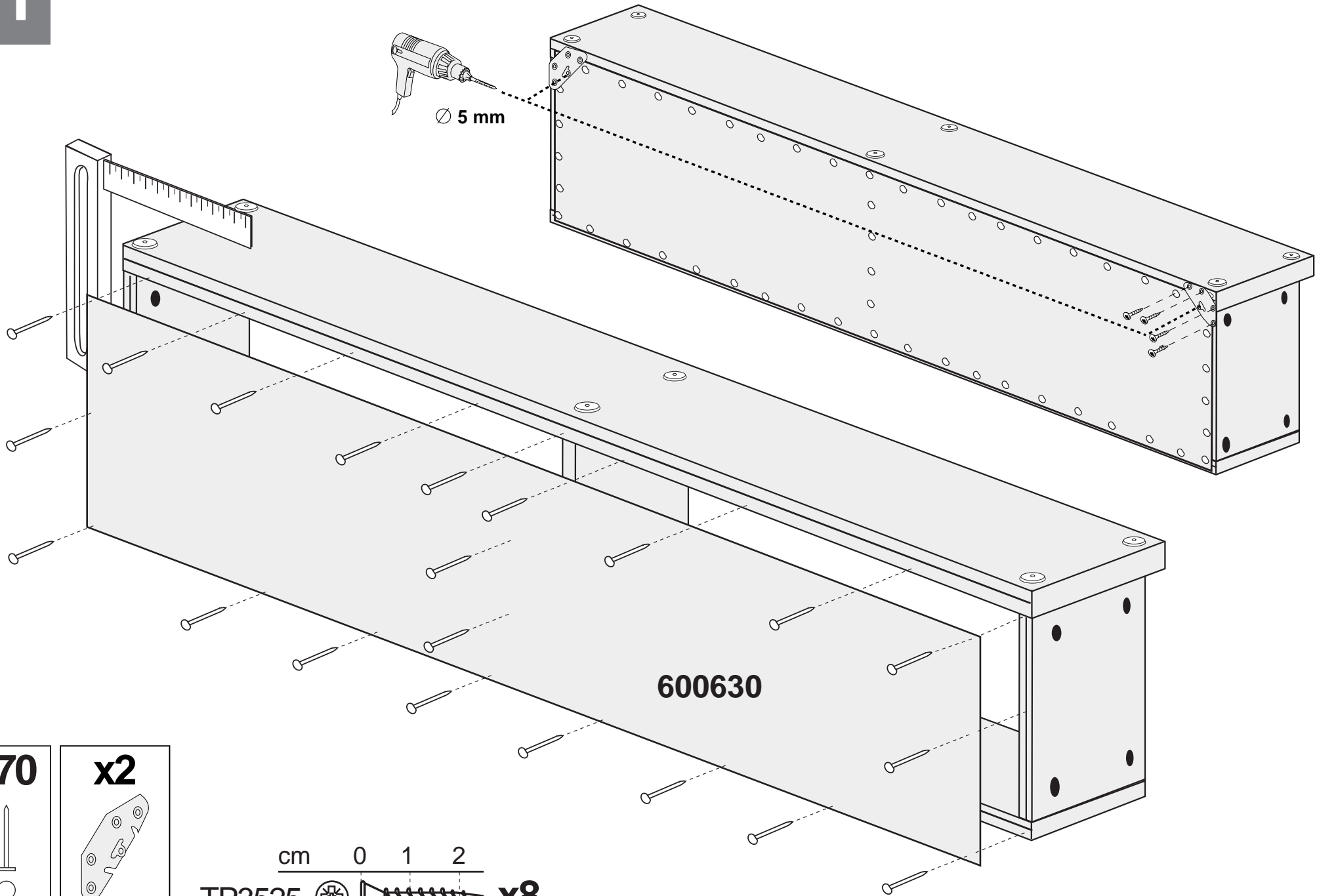
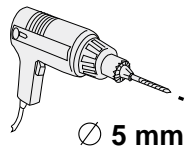

**x70**



P1010

**x2**

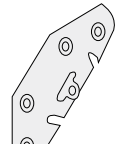

ECG

cm 0 1 2



TP3525 **x8**



**a**

?

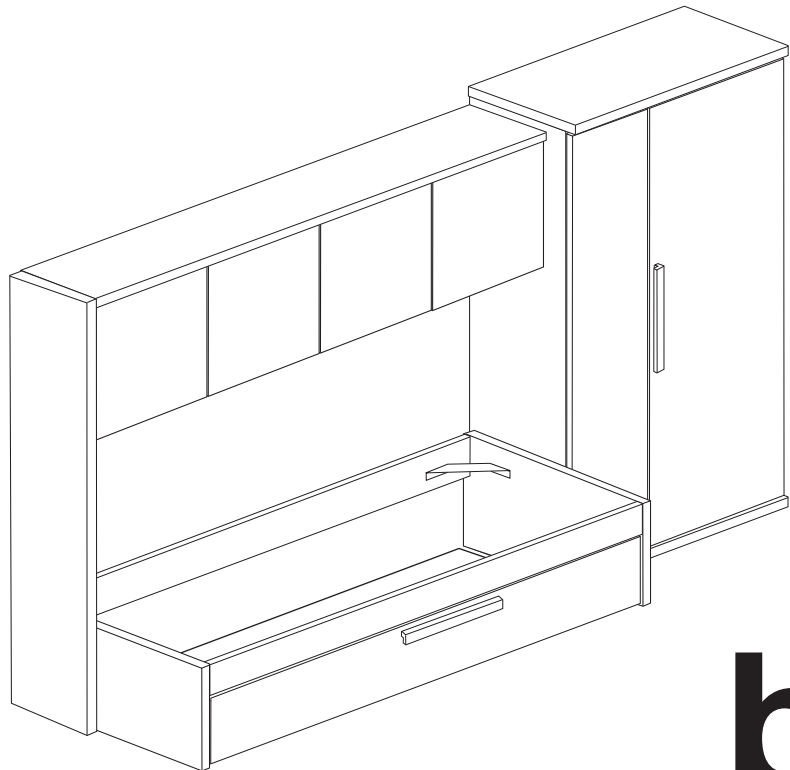



**b**

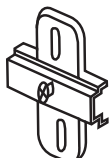

# 12a

**x8**  
  
**BA35S**

cm 0 1 2

**TCK0311**  **x8**  
**TV3135**  **x16**

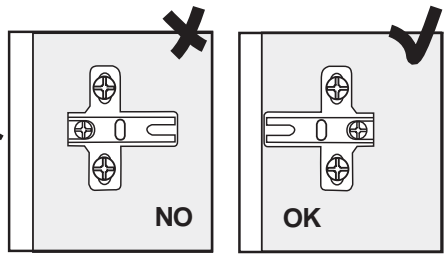
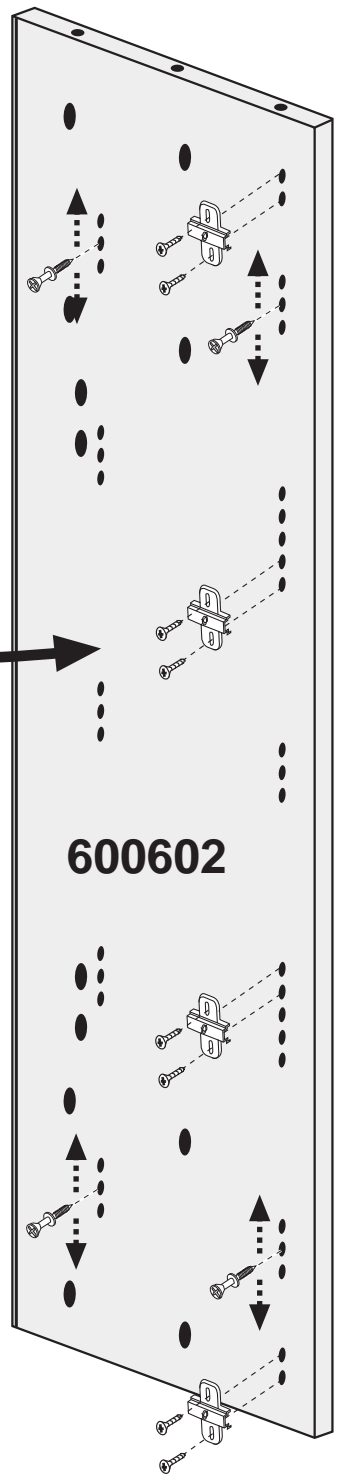
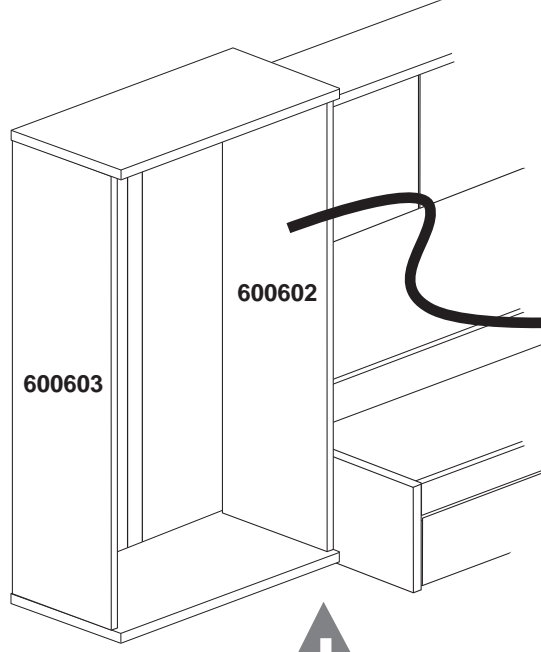
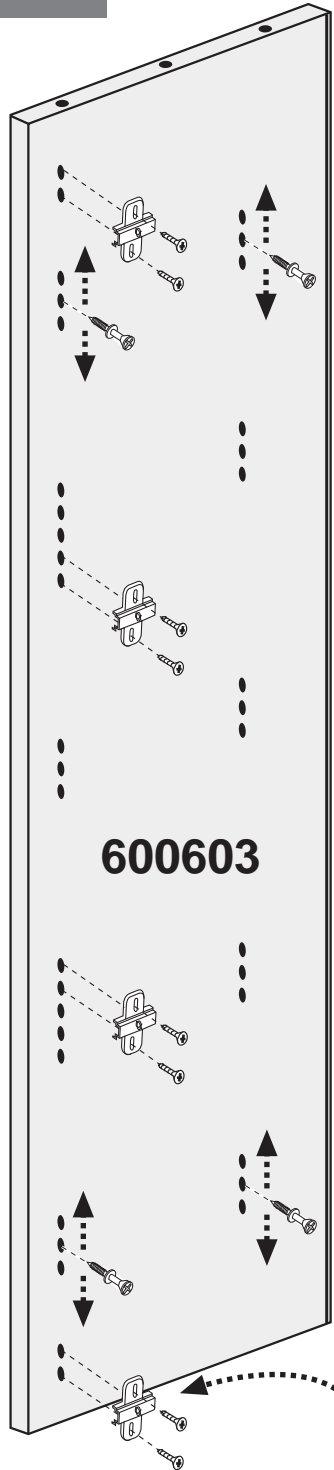

# 13a

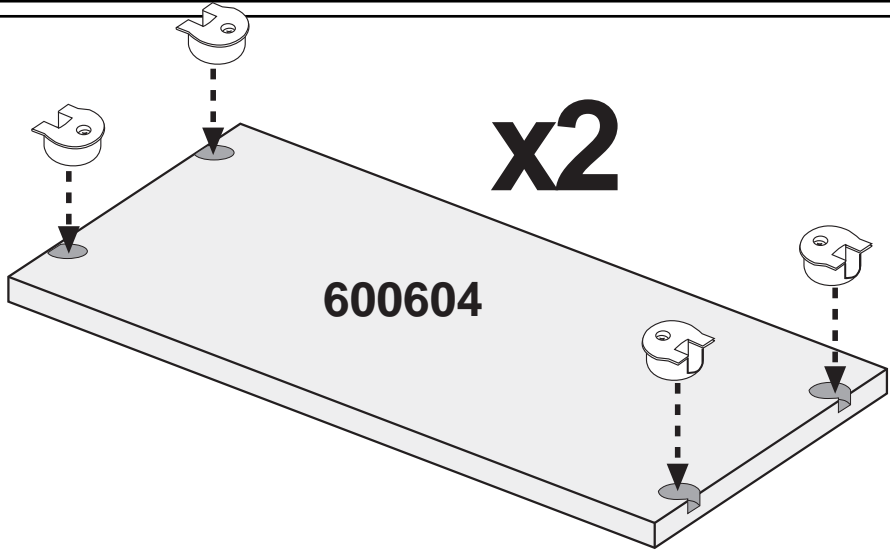

**x8**  
  
**SKM16**

14a

cm 0 1 2 3 4 5 6

TA760  x12

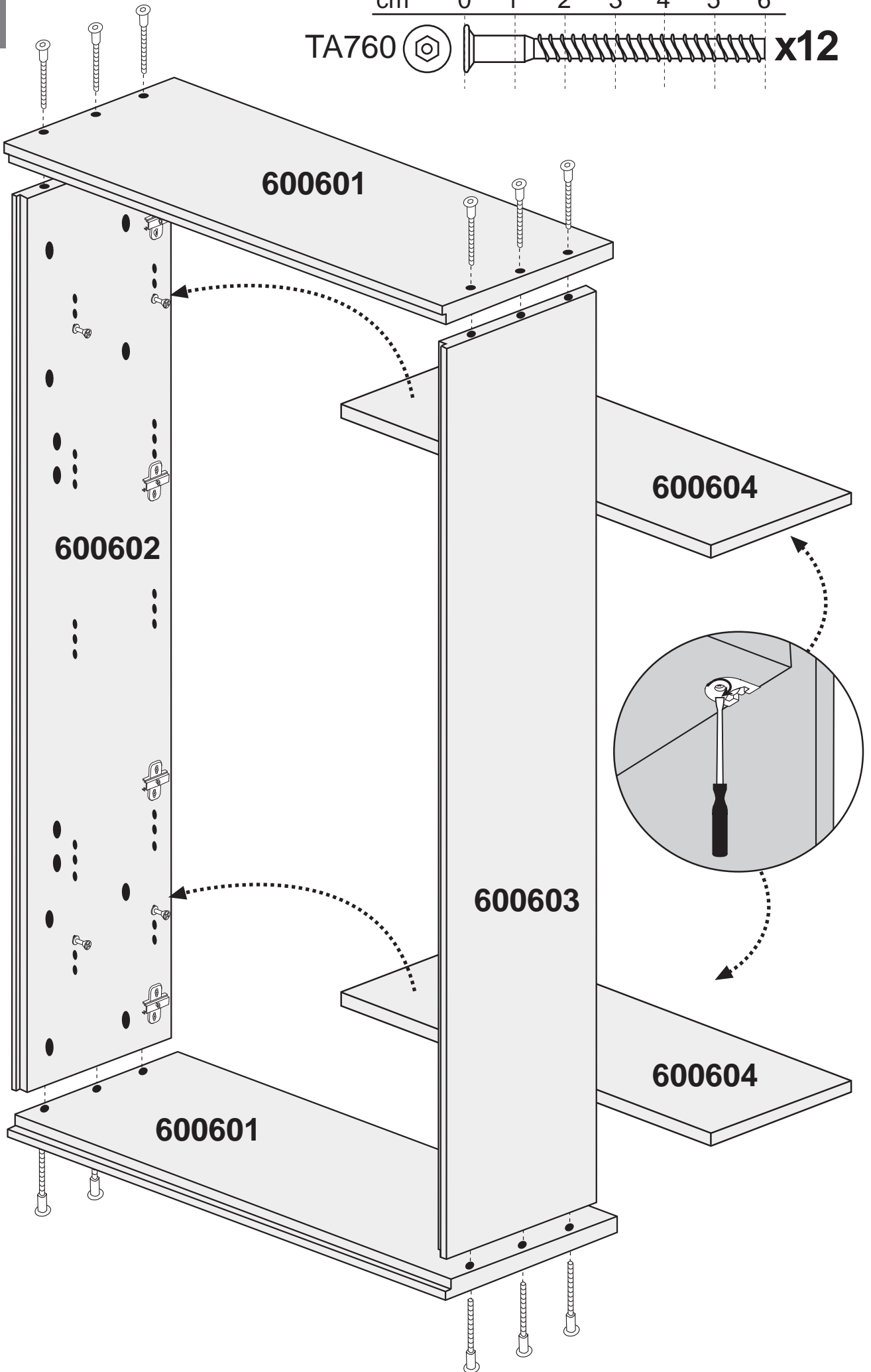

# 15a

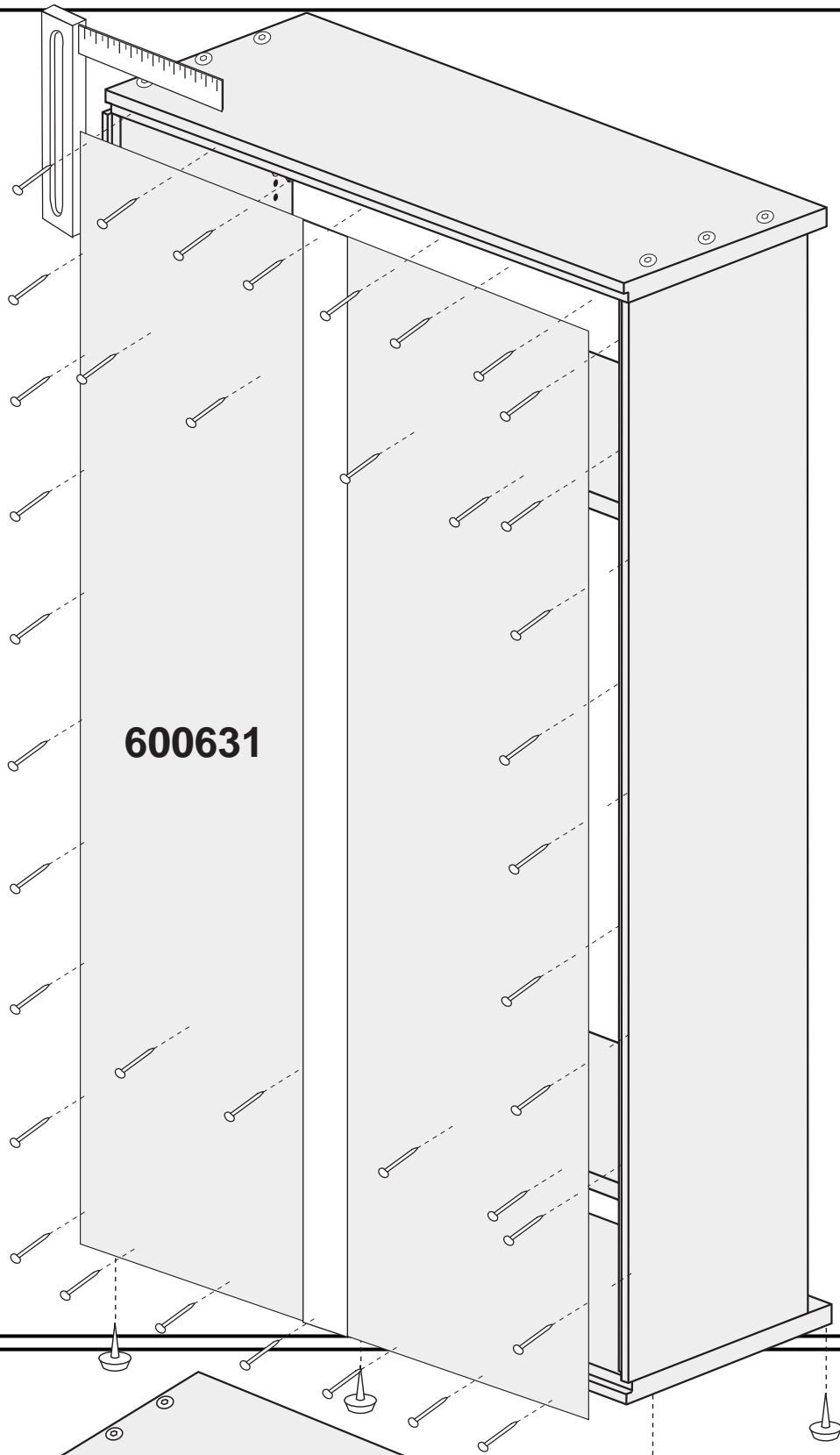

600631

x80



P1010

x6



TSM

# 16a

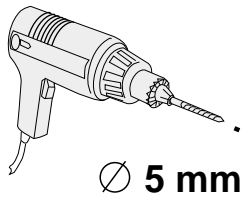

∅ 5 mm

cm 0 1 2

TP3525



x8

x2

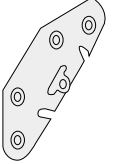

ECG

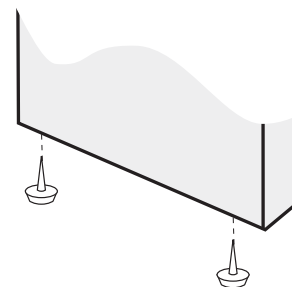
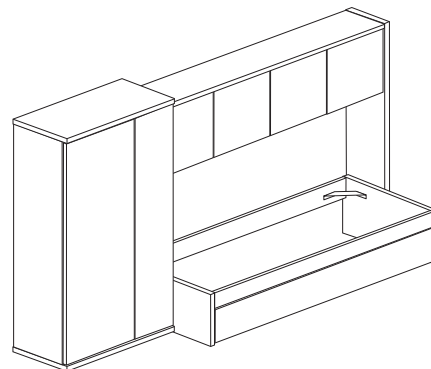
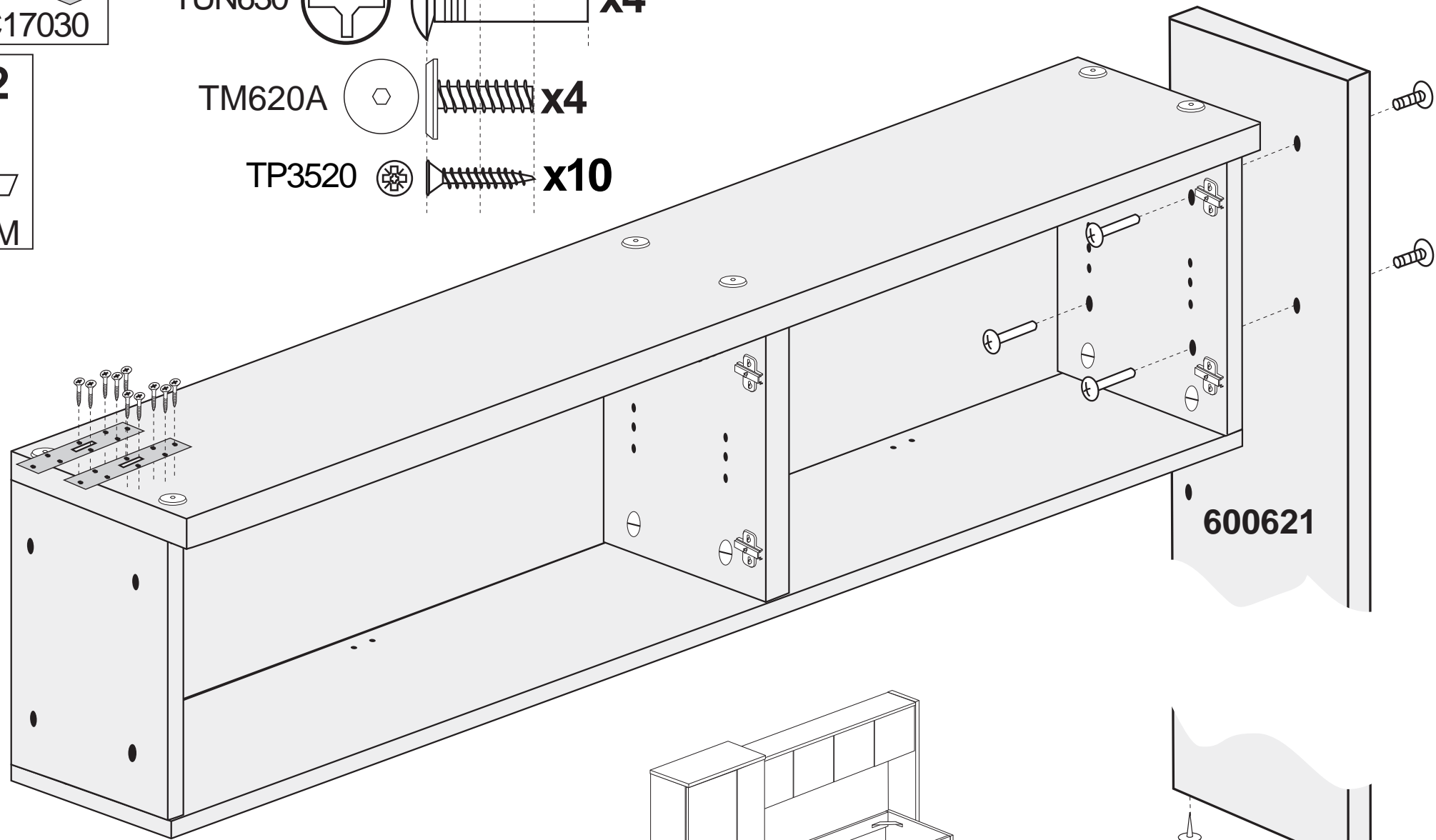
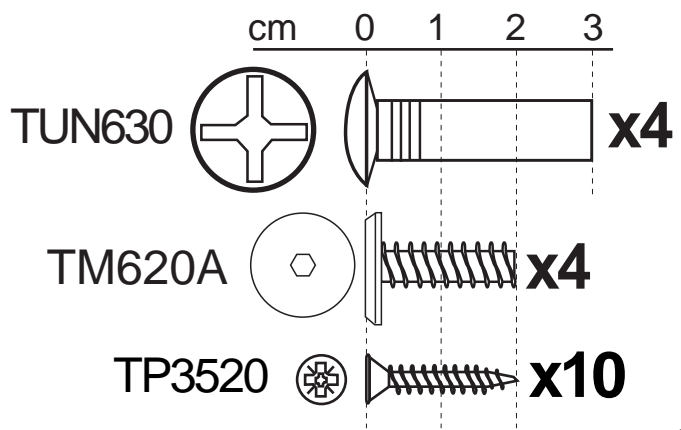
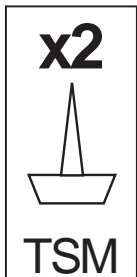
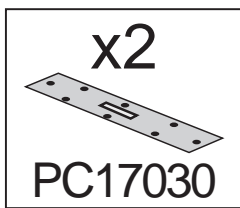

17a

cm 0 1 2 3

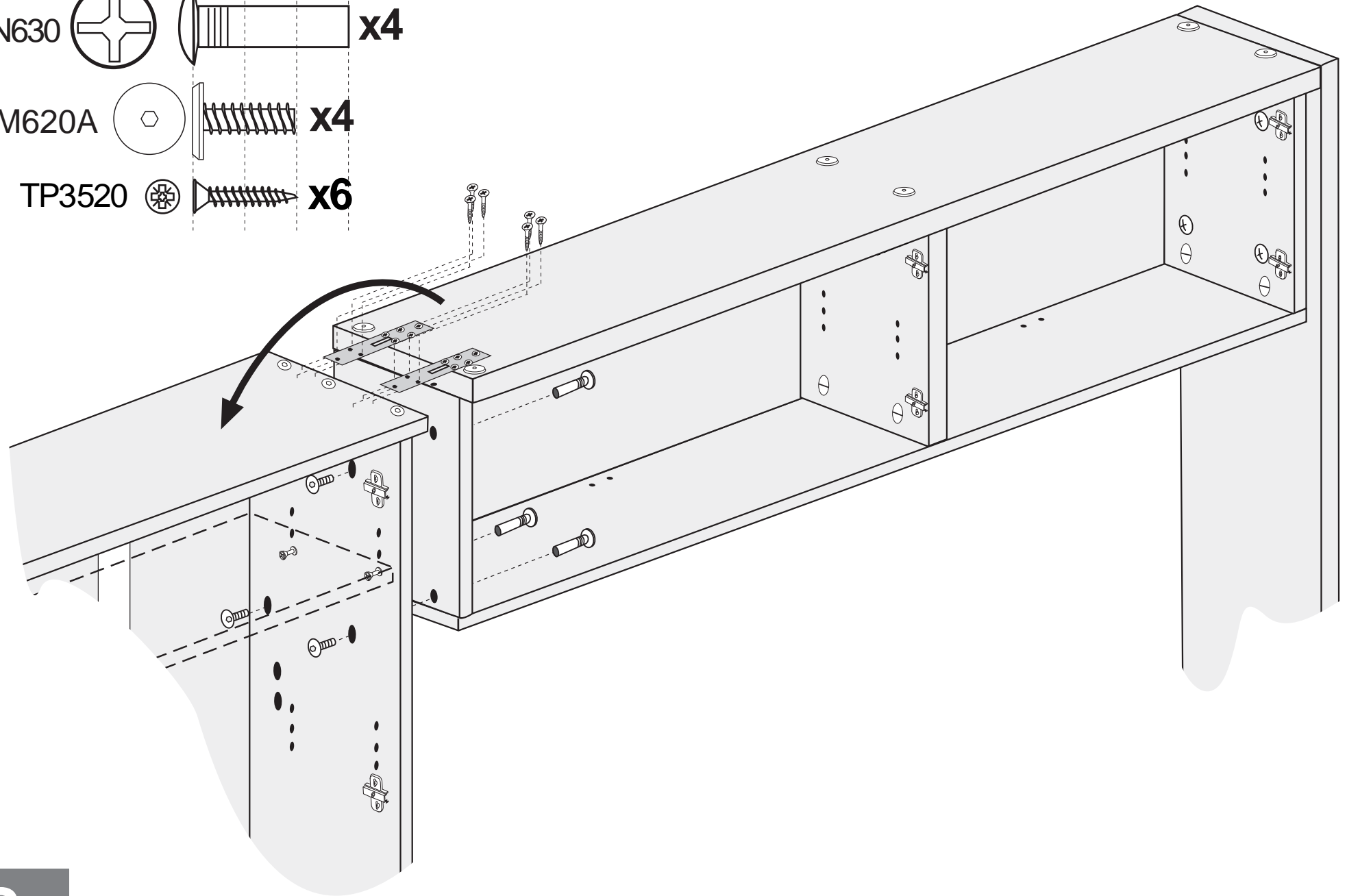
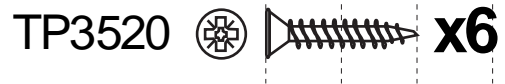
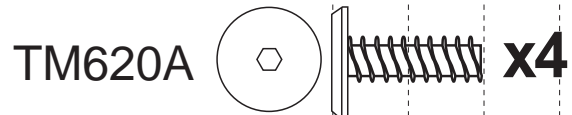
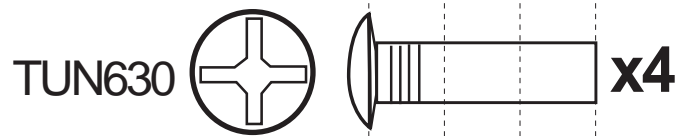

18a

x2

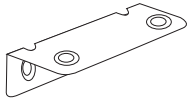

EA2020

cm 0 1 2

TV3135



x8

x4



TA4BL

600622

cm 0 1 2 3 4 5 6

TA760



x4

19a

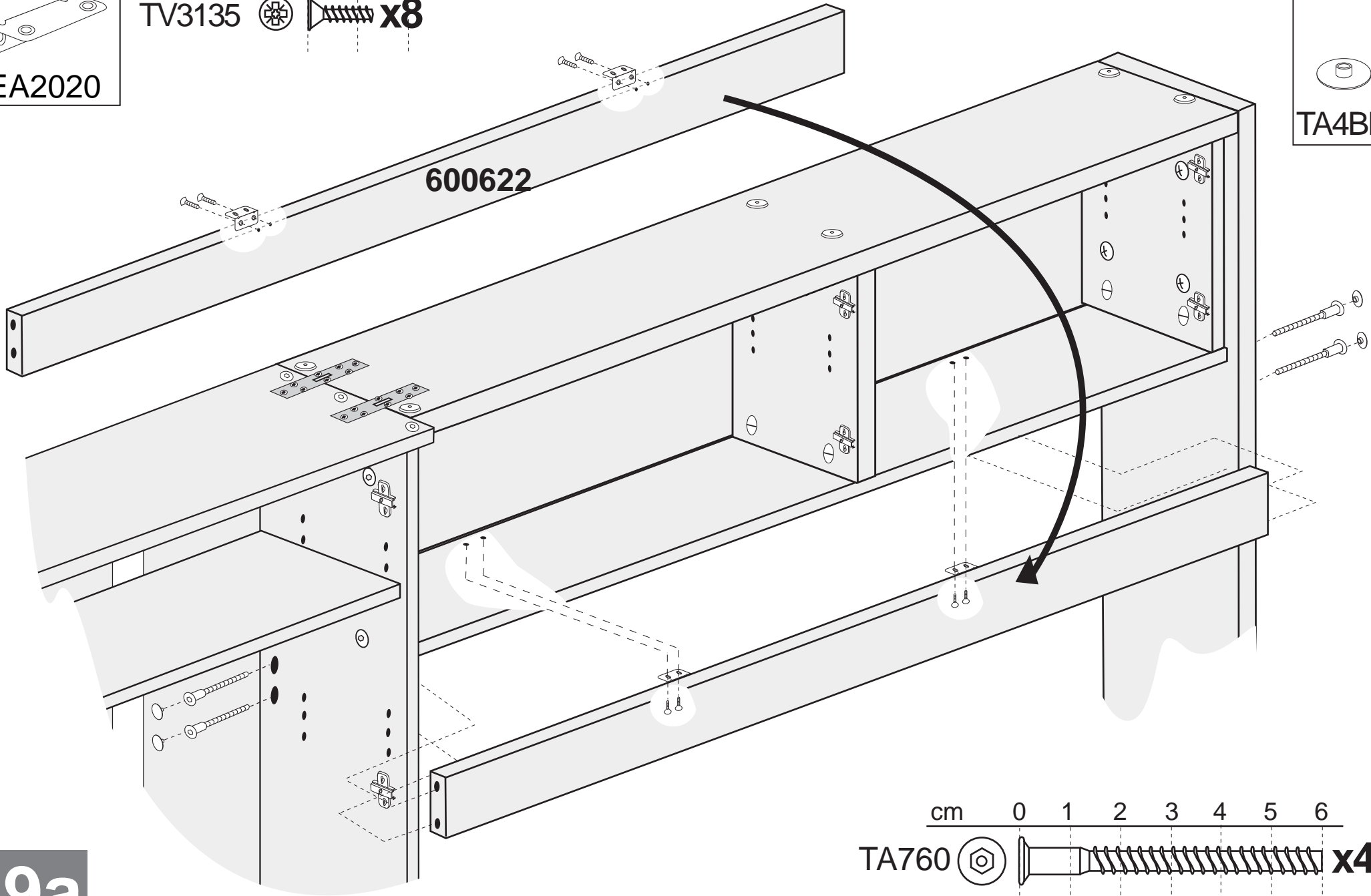

x2



SBO22P

x4



TAPALU

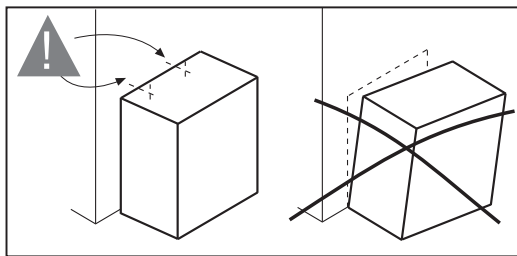

ADVERTENCIA  
AVERTISSEMENT  
WARNING  
AVVERTENZA  
ACHTUNG  
IMPORTANTE

No incluido  
Not included  
Pas inclus

No incluido  
Not included  
Pas inclus

No incluido  
Not included  
Pas inclus

BA860

250mm

20a



cm 0 1 2  
TP3515 x4

x1



BA860

21a

cm 0 1 2 3  
TP3535   x4

x8

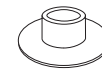

T8BL

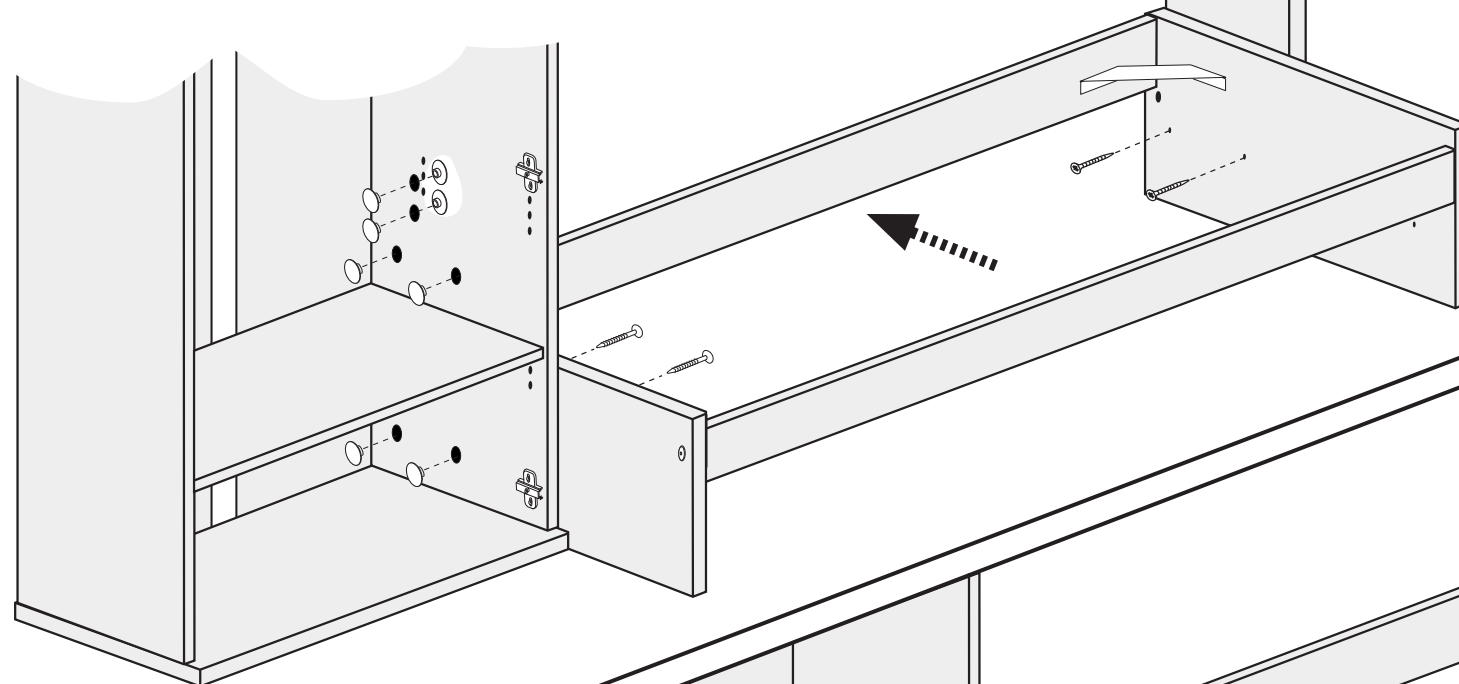

22a

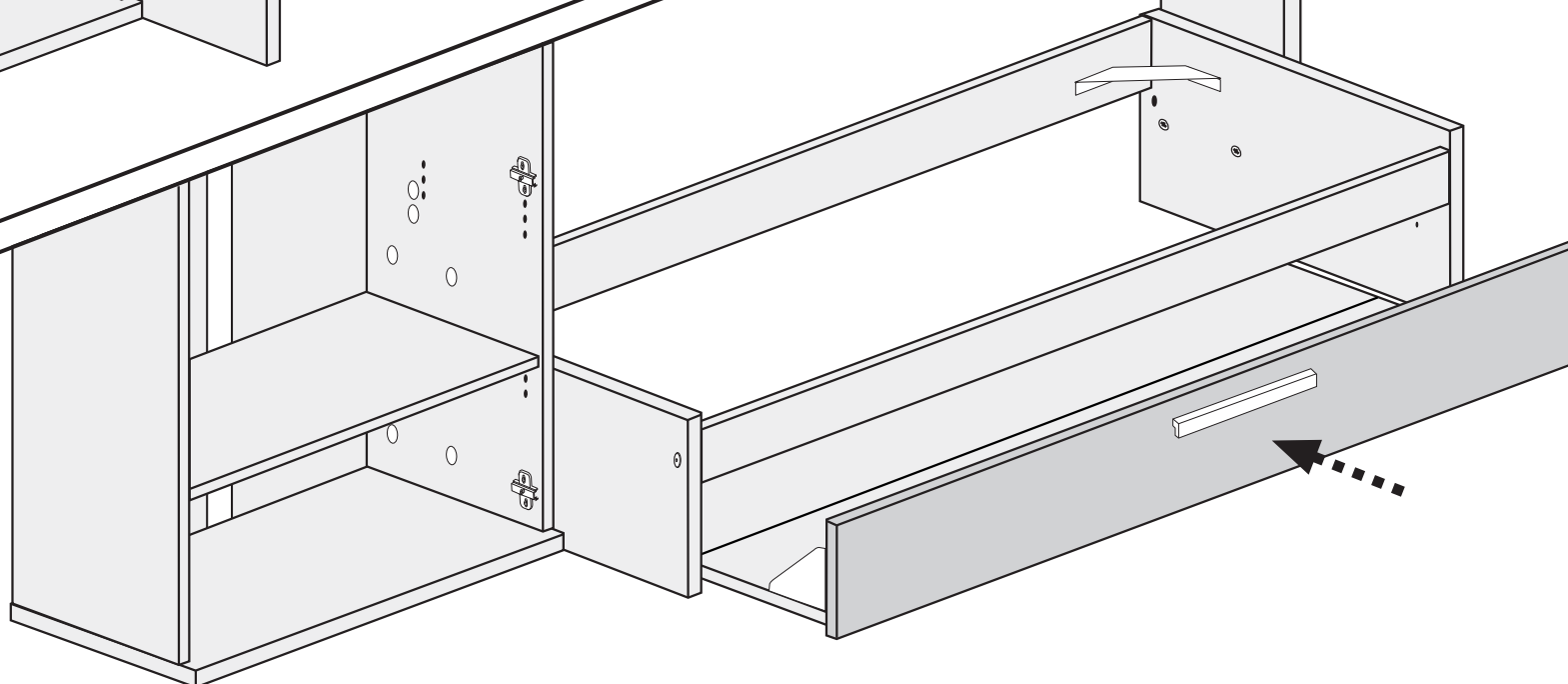



23a

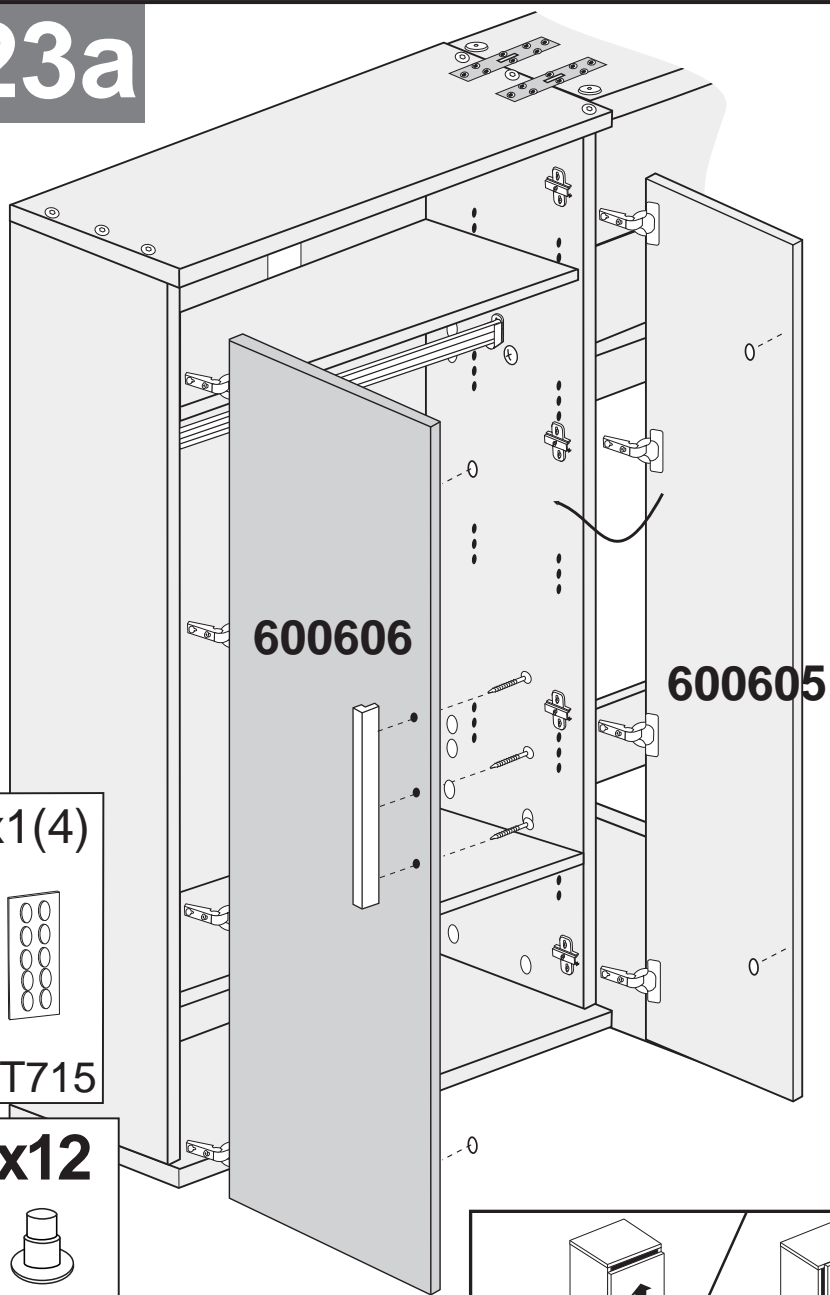

x1(4)

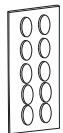

CT715

x12



T5PC

x1



AAB400

x3



TCA4030

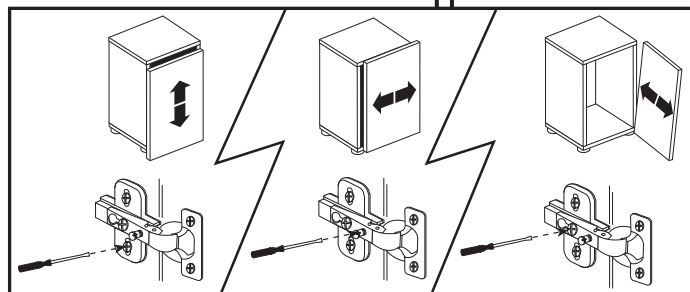

x8



PE3

x1(4)

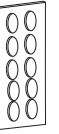

CT715

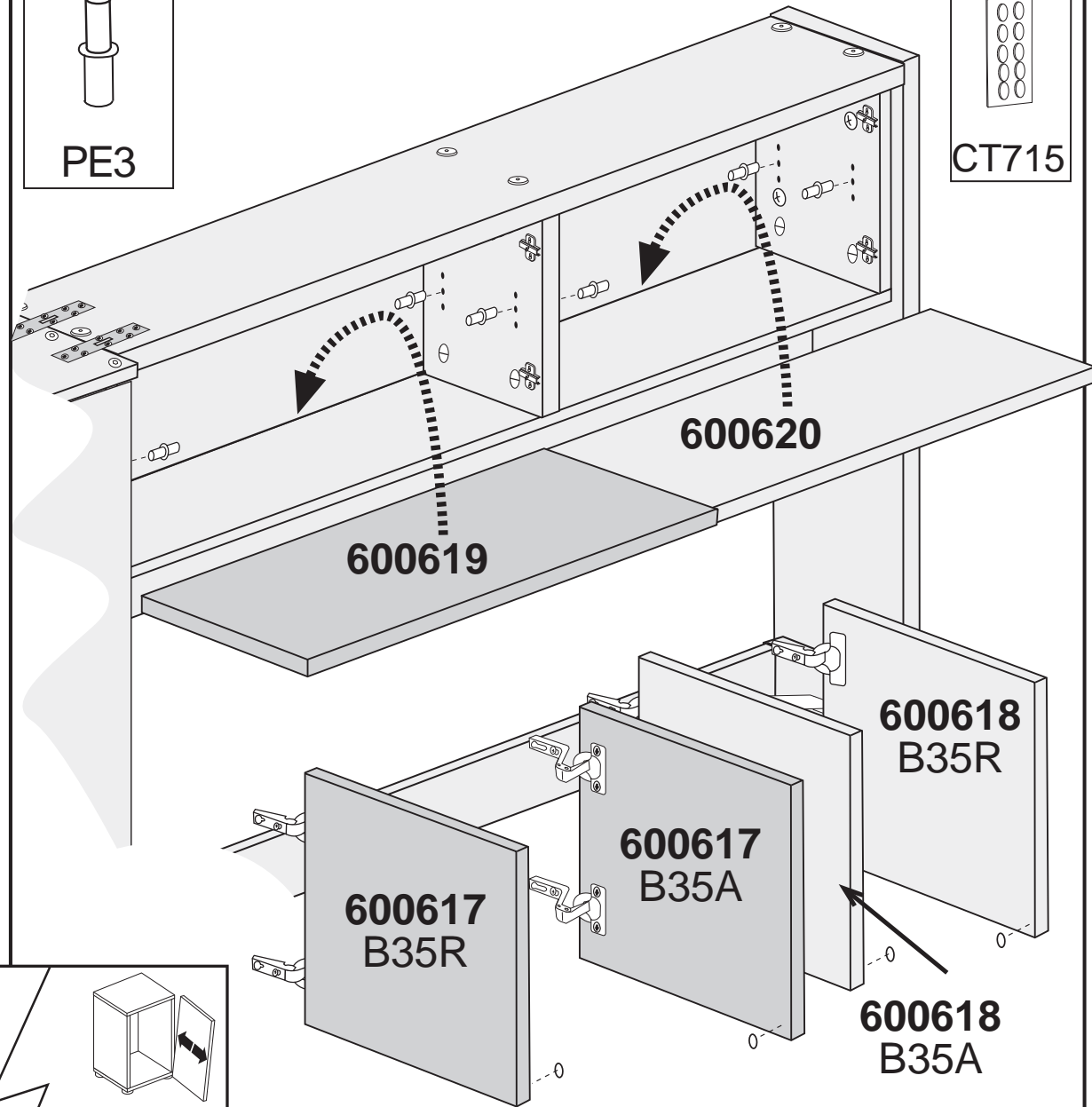

24a

**25a**

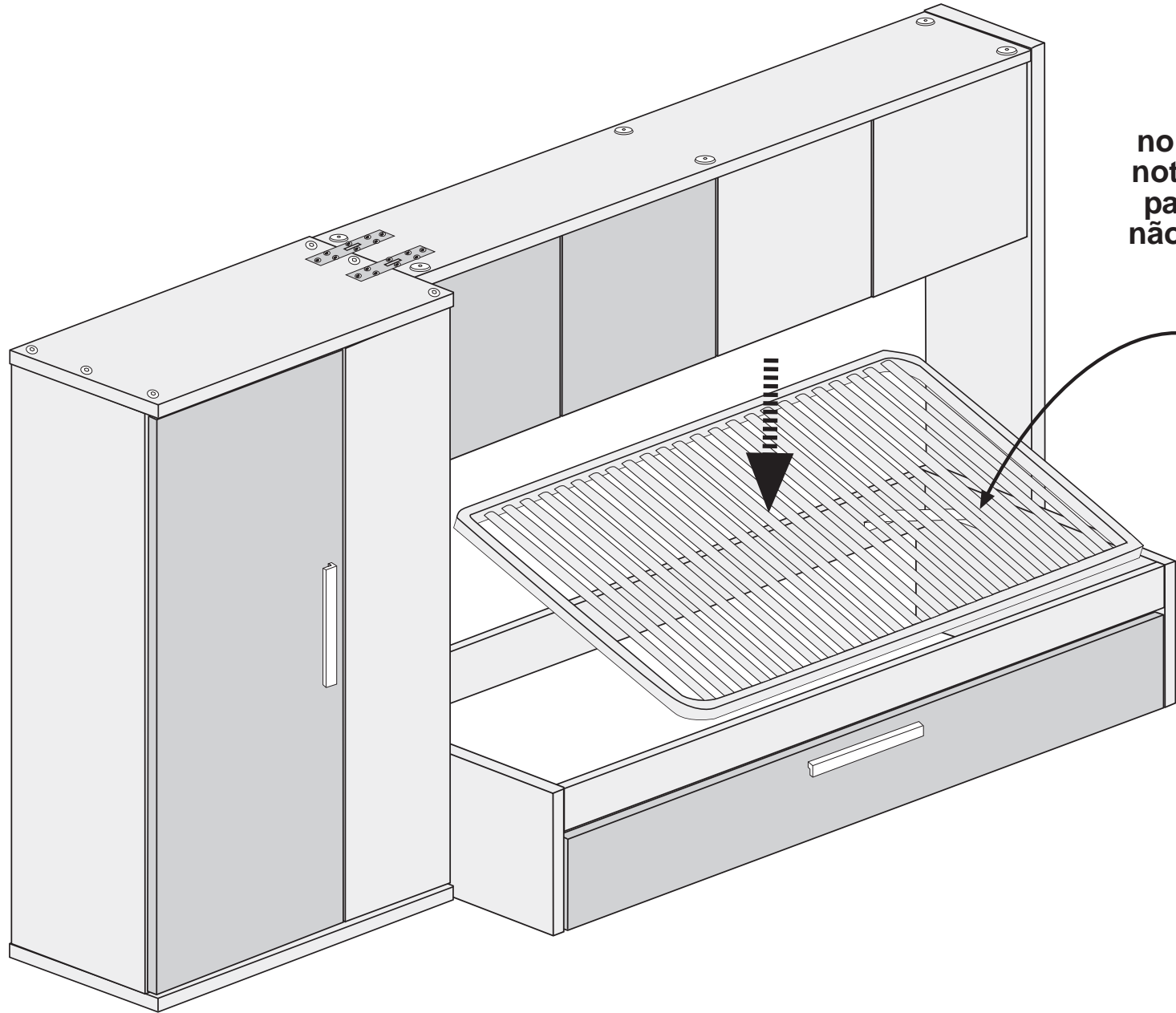

no incluido  
not included  
pas inclus  
não incluído

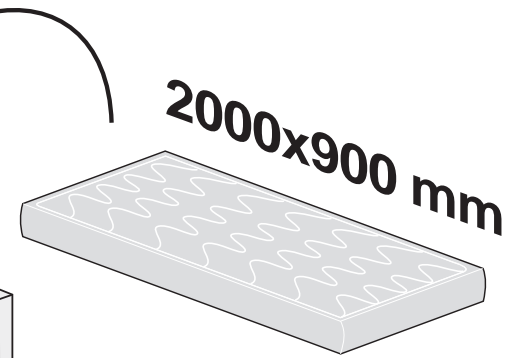

**2000x900 mm**

# 12b

cm 0 1 2

TCK0311  **x8**

TV3135  **x16**

**x8**

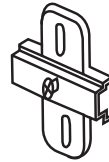

**BA35S**

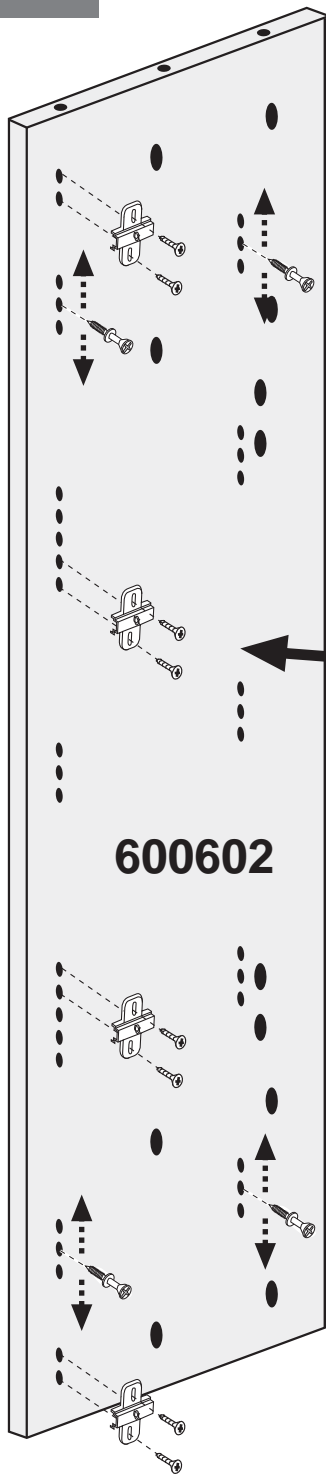

**600602**

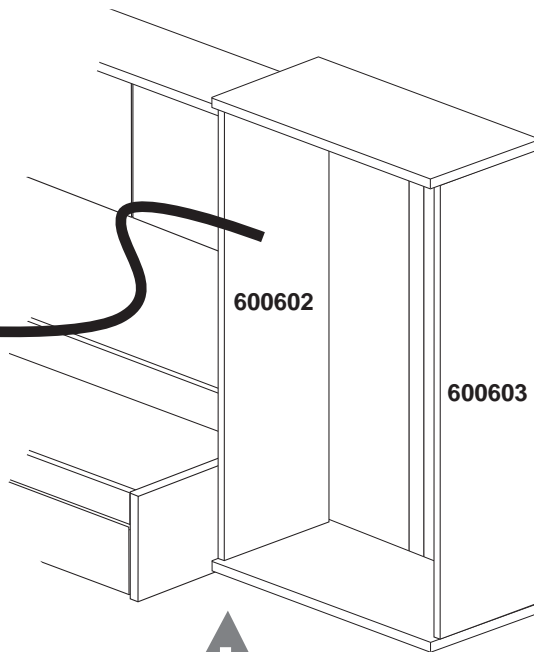

600602

600603

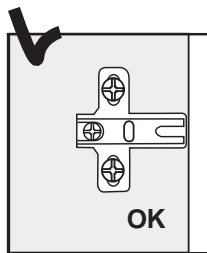

OK

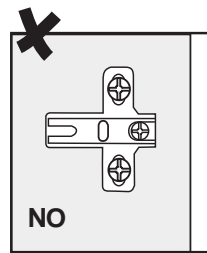

NO

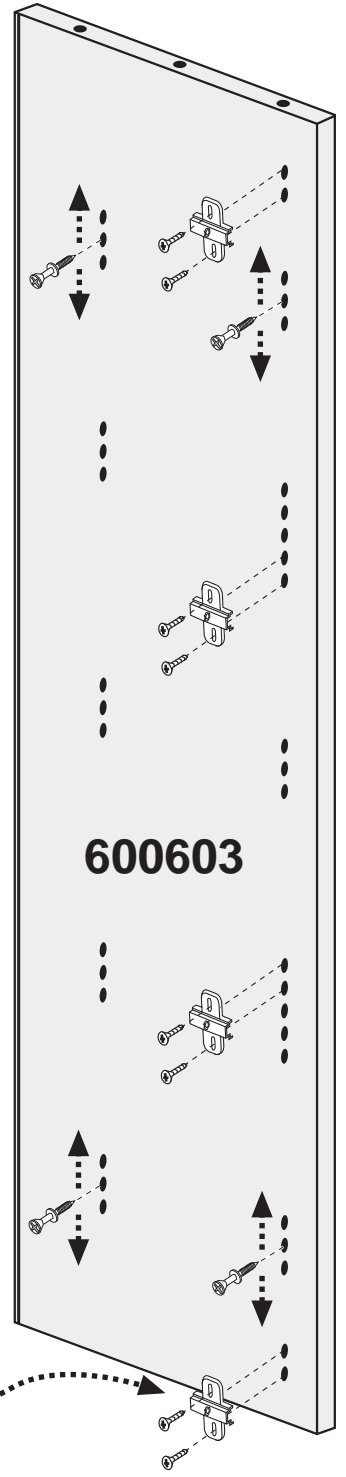

**600603**

# 13b

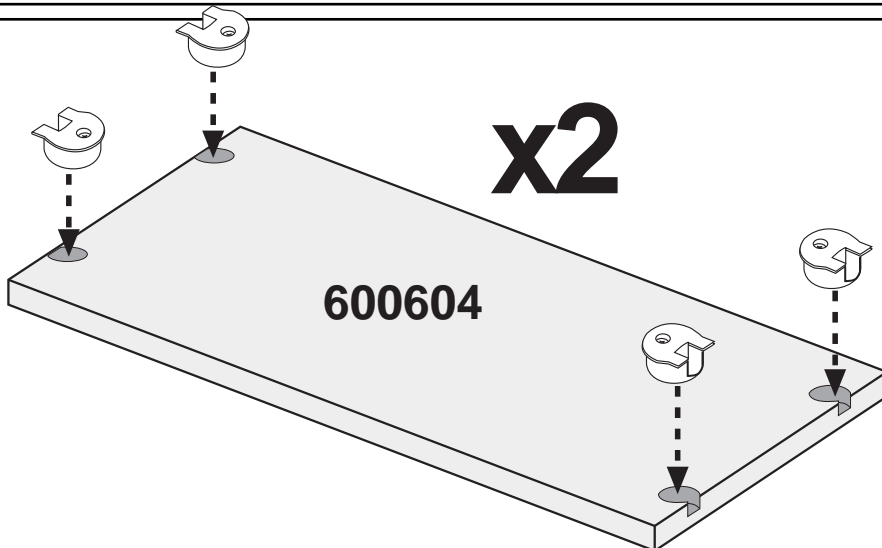

**600604**

**x2**

**x8**



**SKM16**

cm 0 1 2 3 4 5 6

TA760  x12

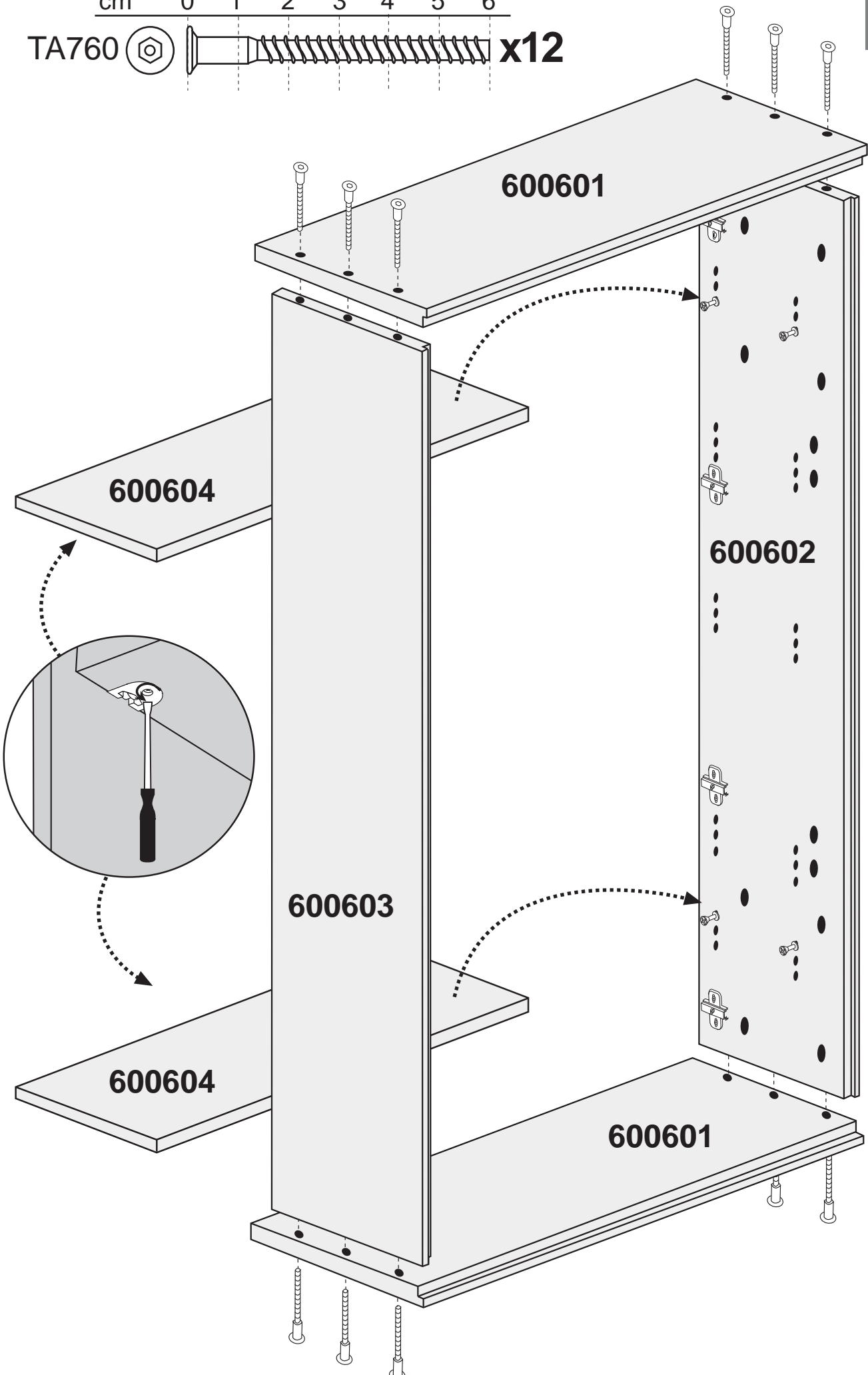

15b

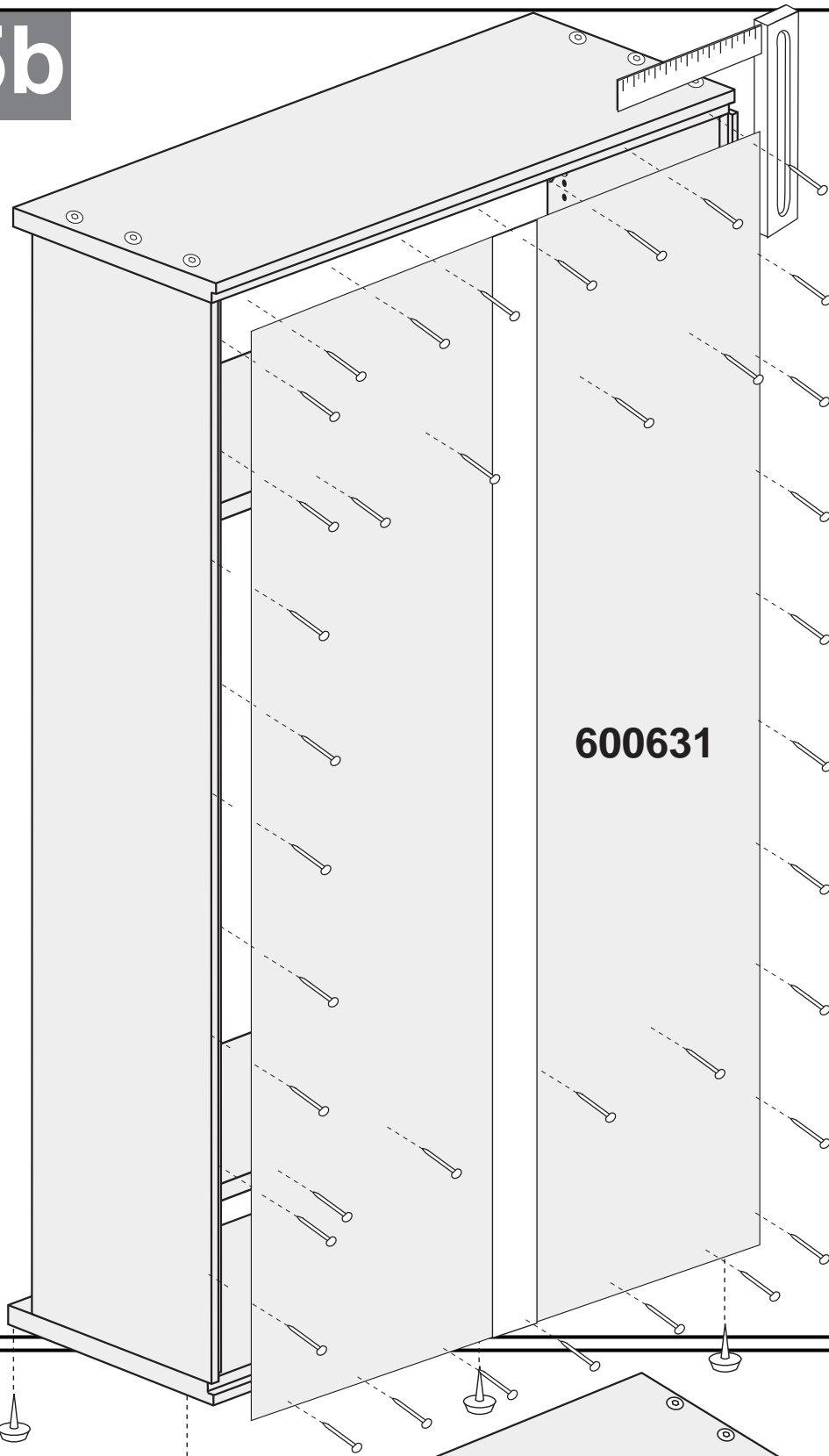

600631

**x80**



P1010

**x6**



TSM

16b

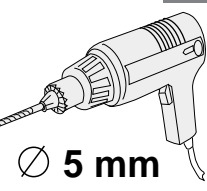
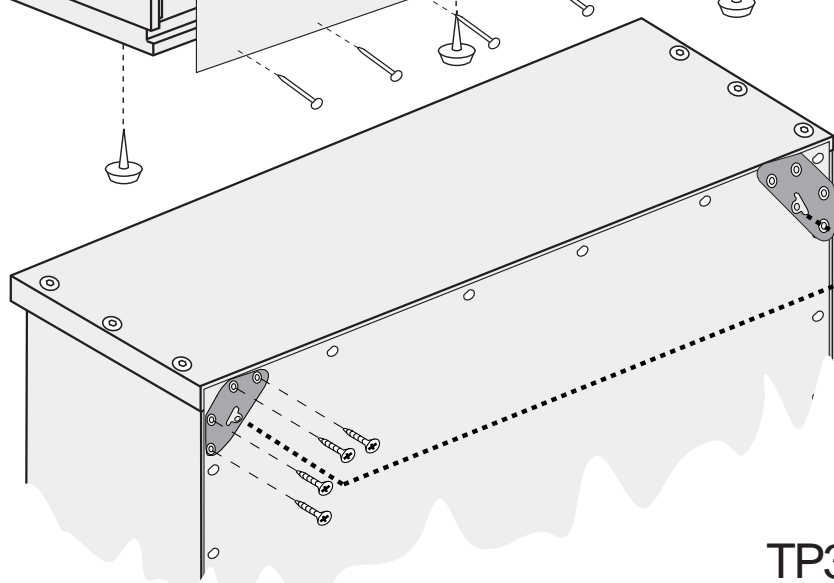

**x2**

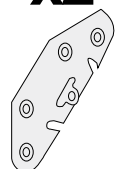



ECG

cm 0 1 2

TP3525  **x8**

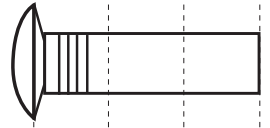
cm 0 1 2 3

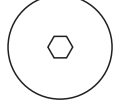
TUN630   **x4**

TM620A   **x4**

TP3520   **x10**

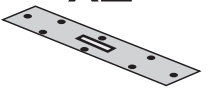
**x2**  
  
PC17030

**x2**  
  
TSM

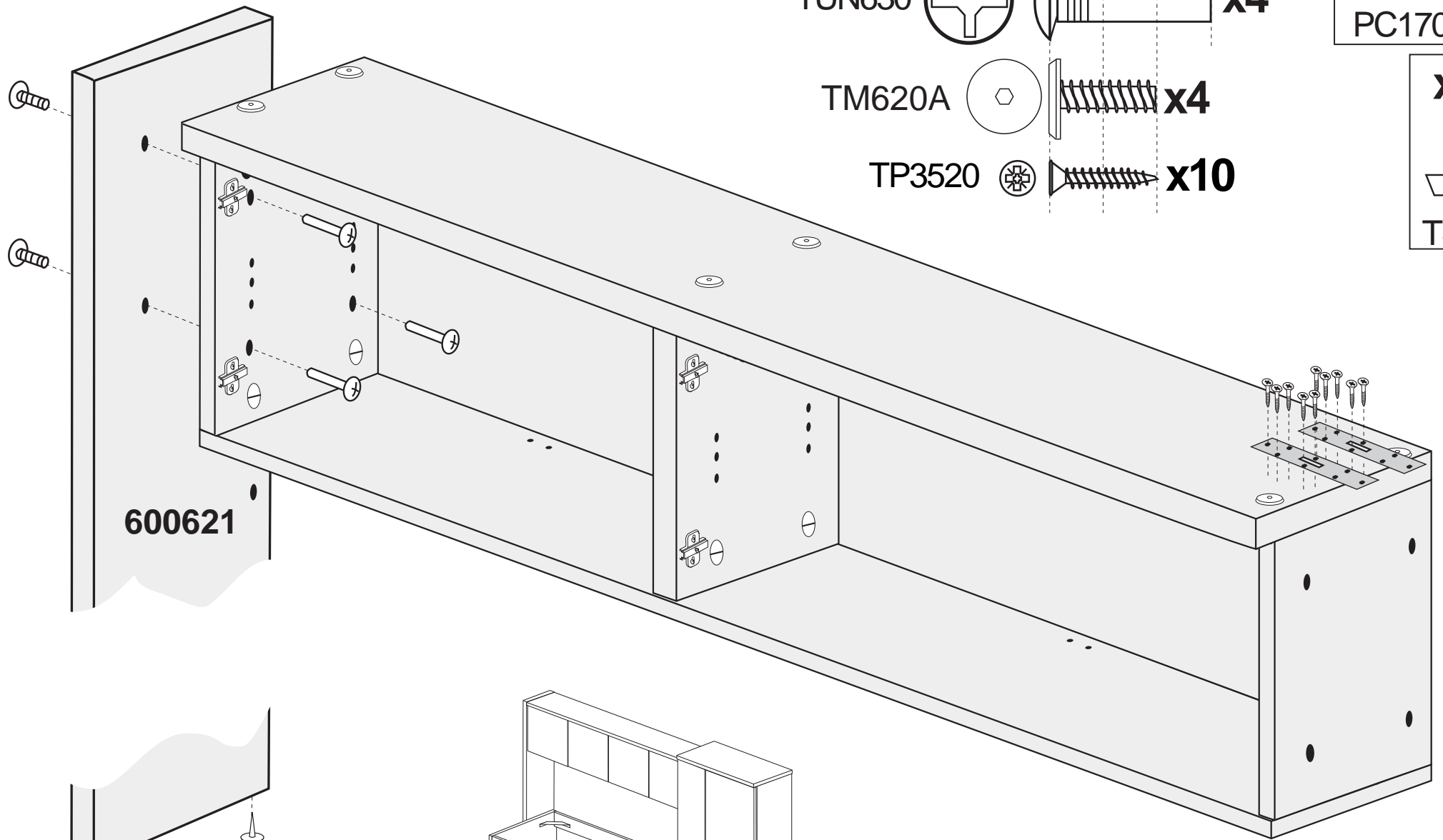

600621

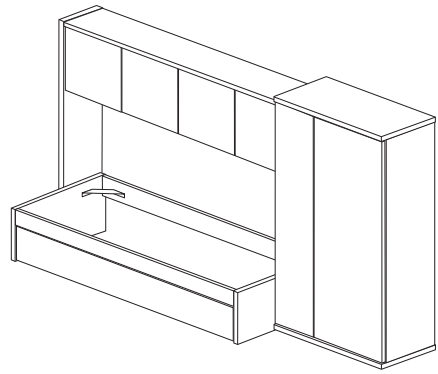
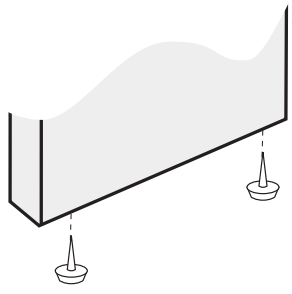

**17b**

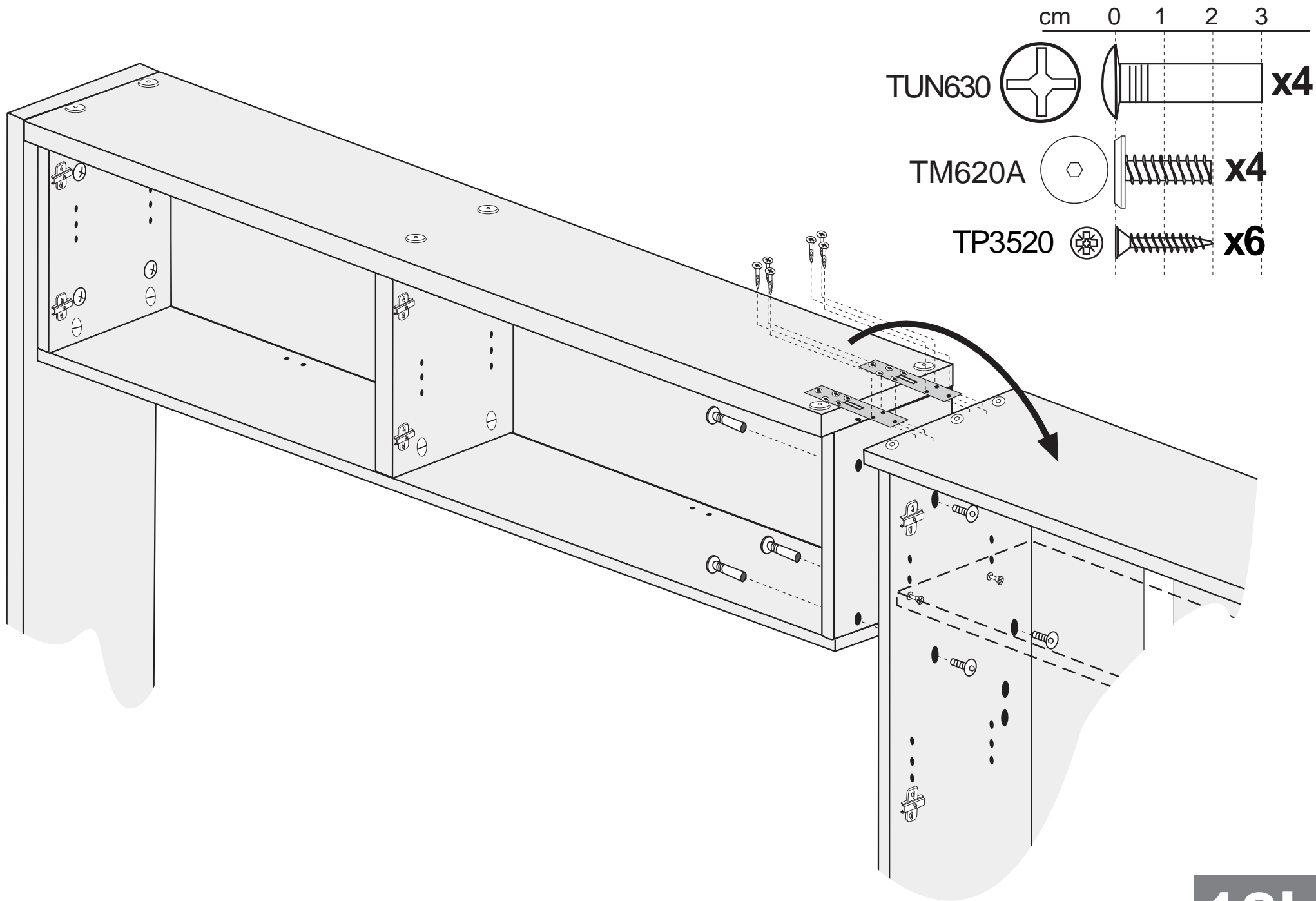

x4



TA4BL

cm 0 1 2

TV3135 x8

x2

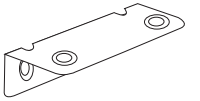

EA2020

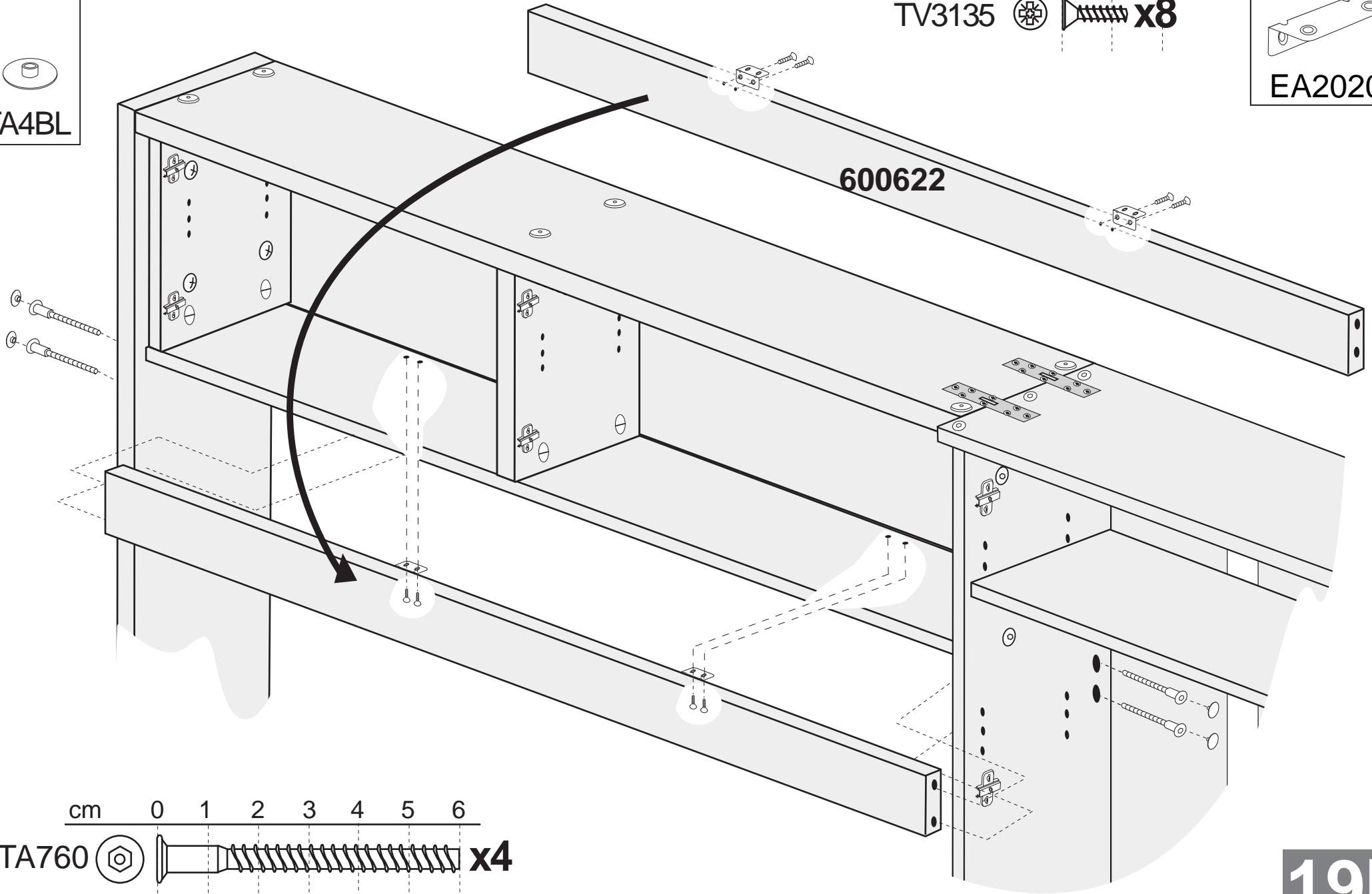

600622

cm 0 1 2 3 4 5 6

TA760 x4

19b



ADVERTENCIA  
AVERTISSEMENT  
WARNING  
AVVERTENZA  
ACHTUNG  
IMPORTANTE

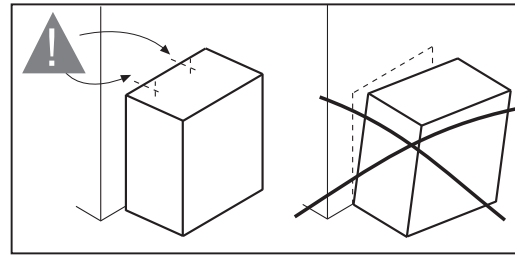

**x4**  
  
**TAPALU**

**x2**  
  
**SBO22P**

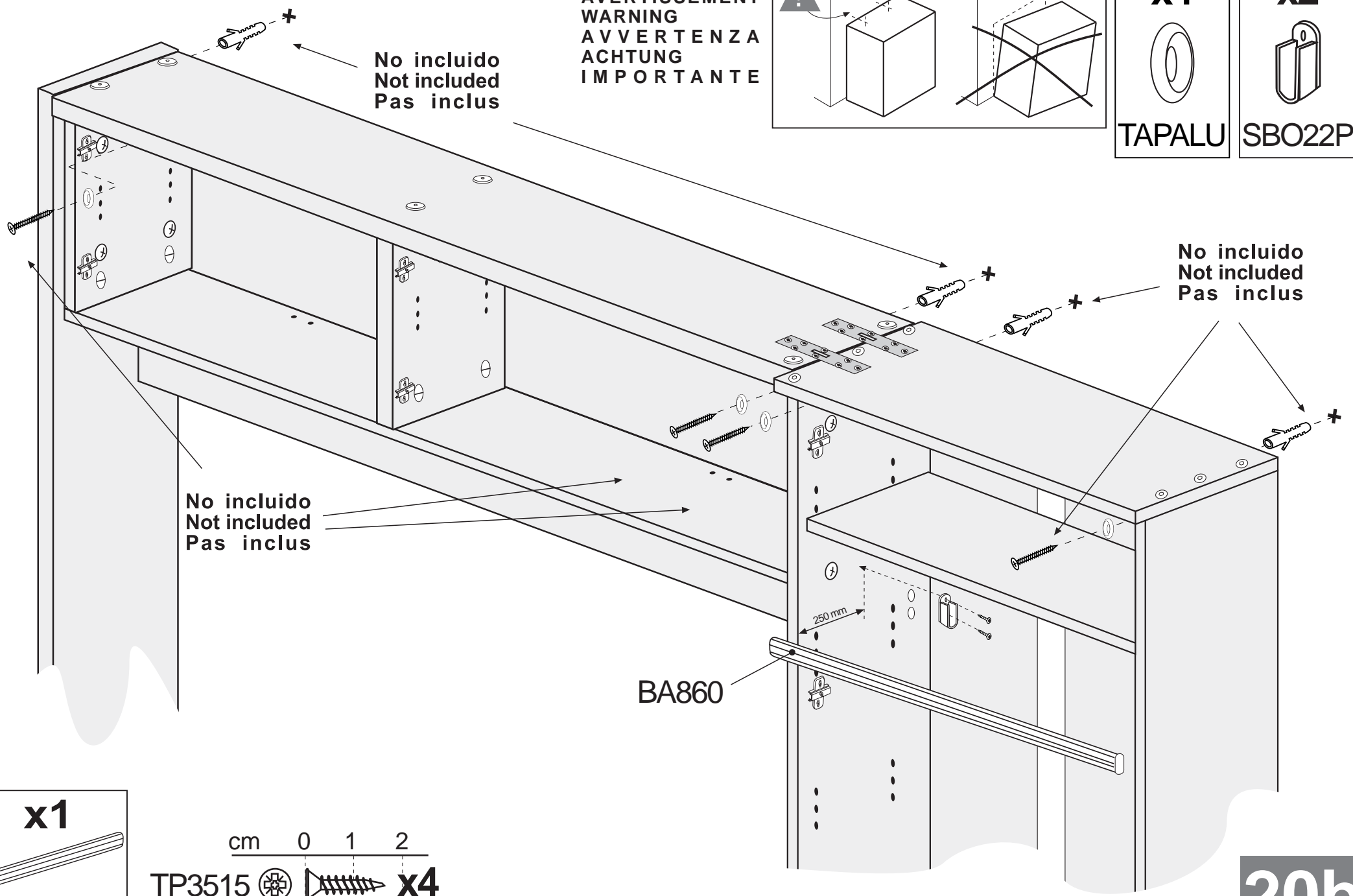

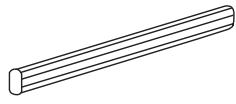
**x1**  
  
**BA860**

cm 0 1 2  
**TP3515**  **x4**

x8

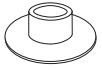

T8BL

cm 0 1 2 3  
TP3535  x4

21b

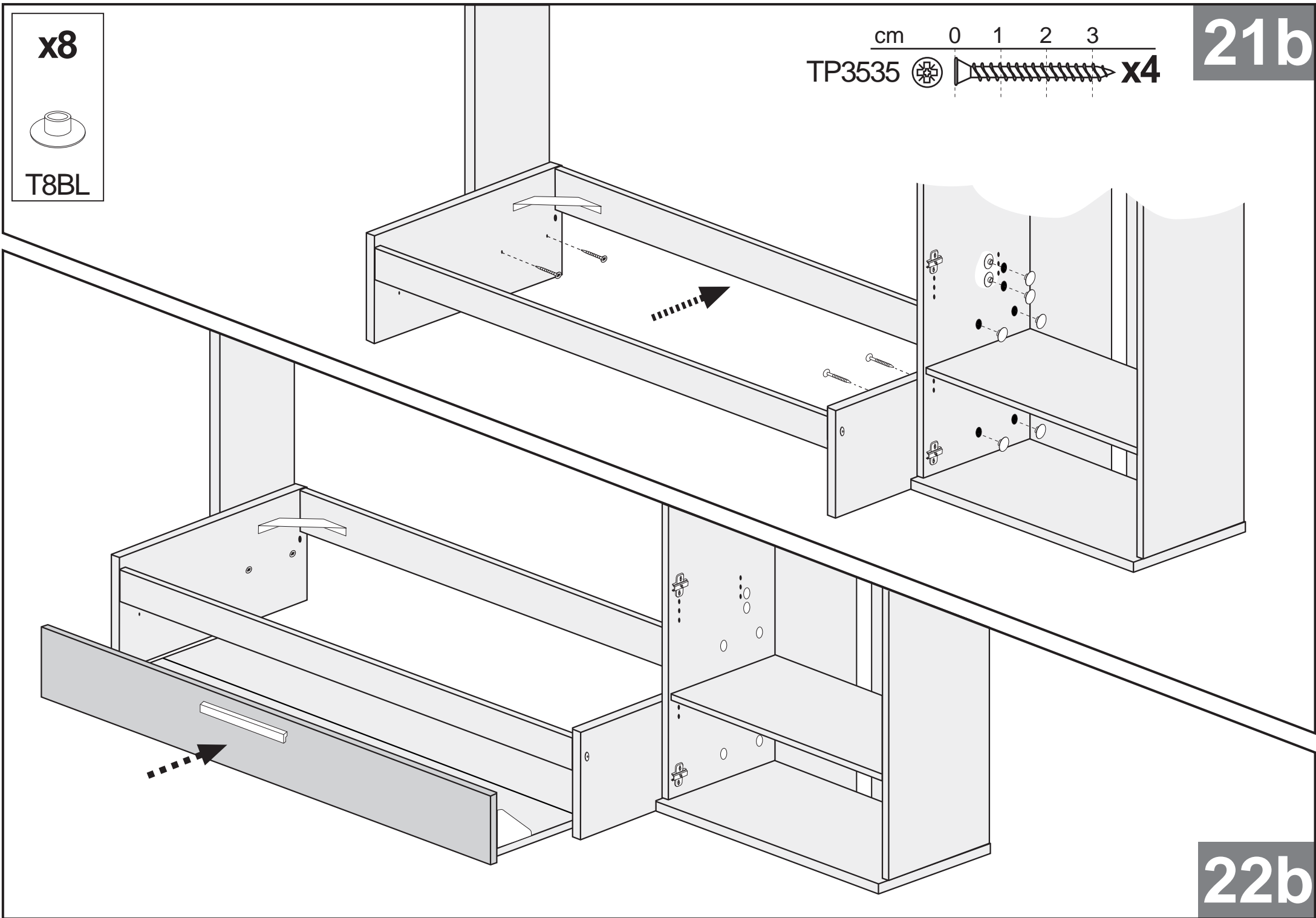

22b

23b

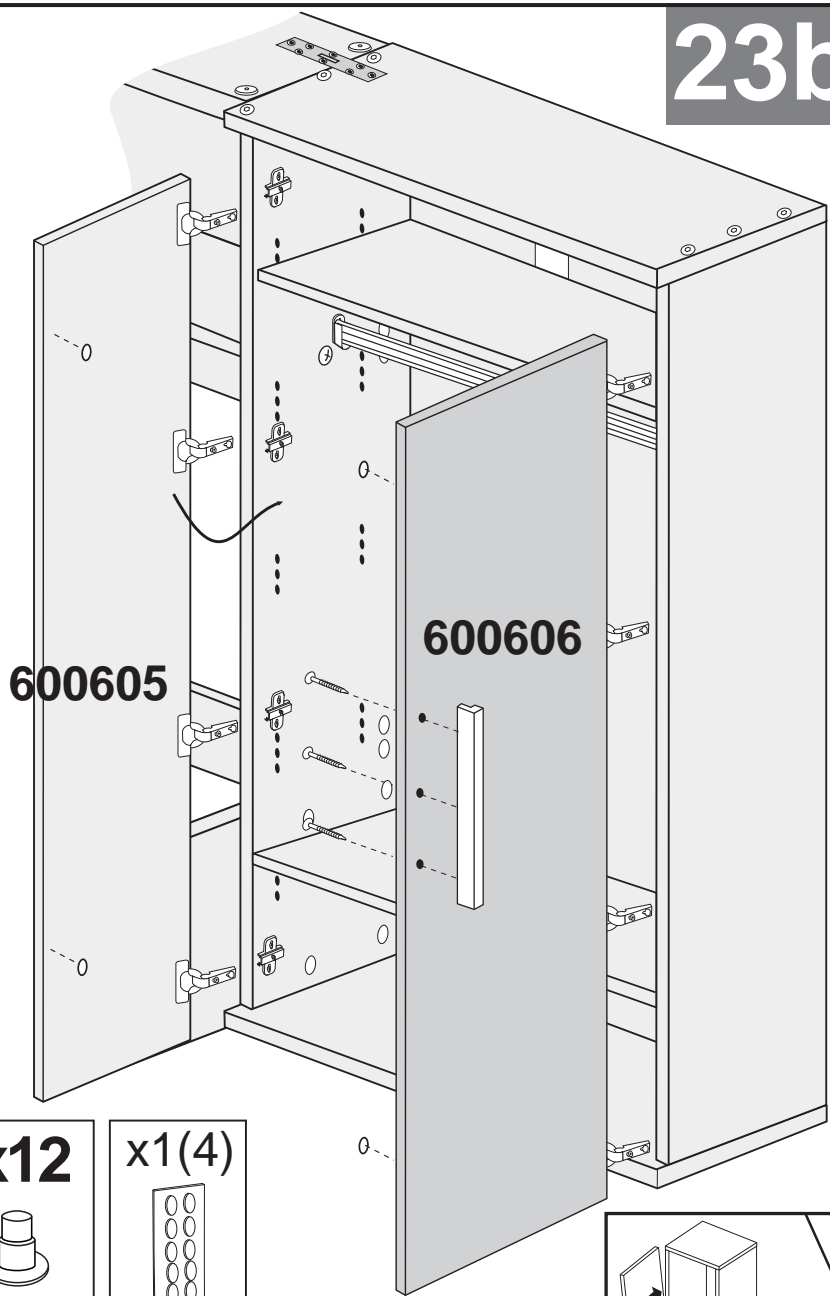

**x12**  
  
 T5PC

**x1(4)**  
  
 CT715

**x1**  
  
 AAB400

**x3**  
  
 TCA4030

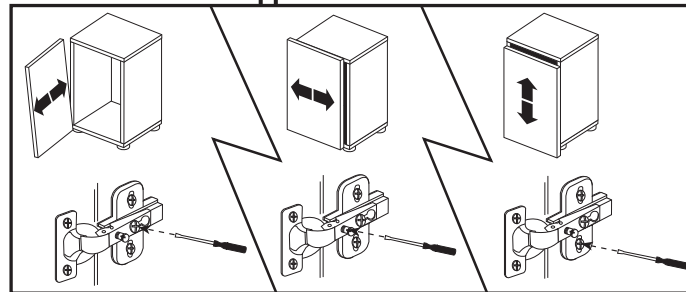

24b

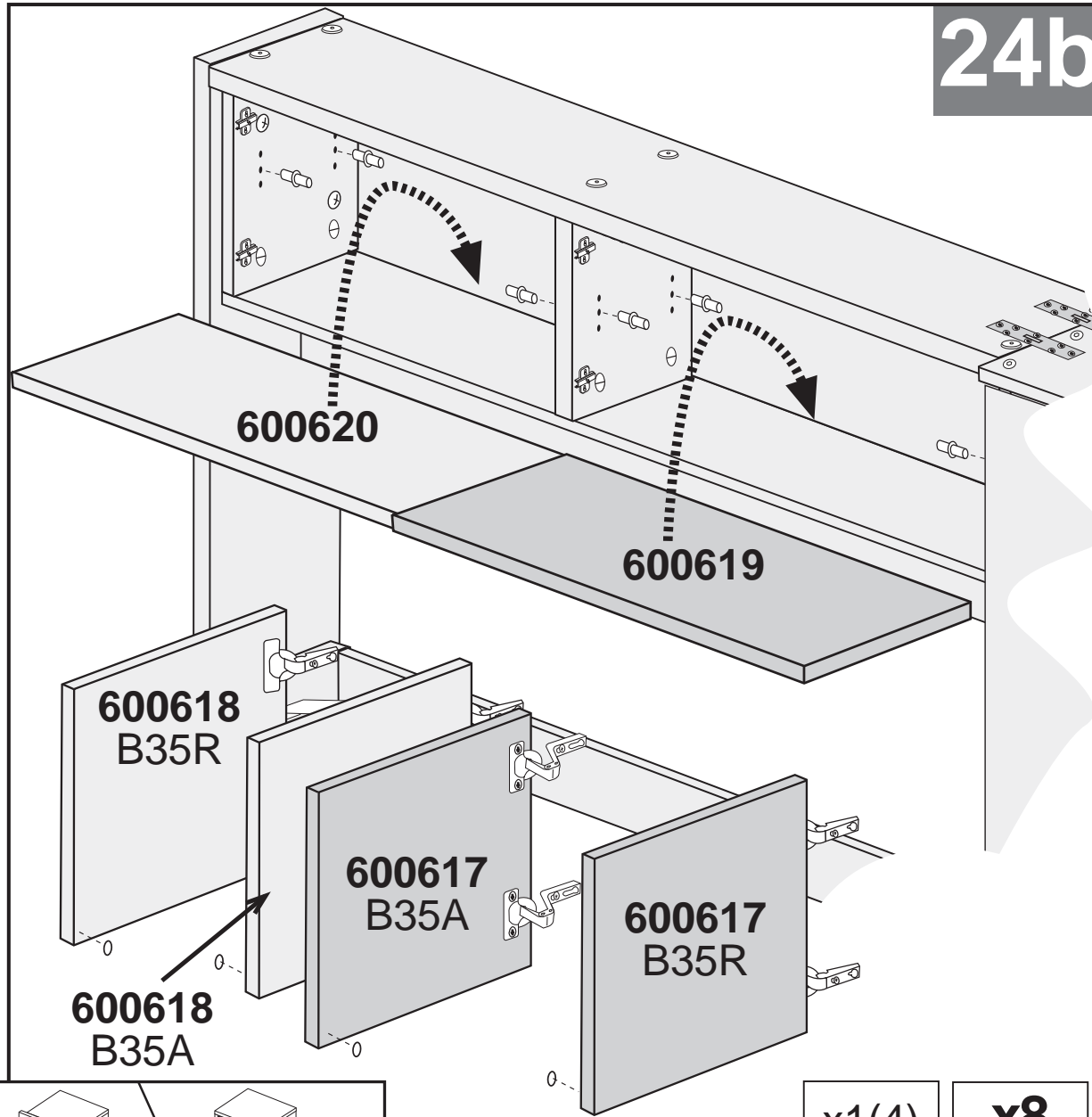

**x1(4)**  
  
 CT715

**x8**  
  
 PE3

# 25b

no incluido  
not included  
pas inclus  
não incluído

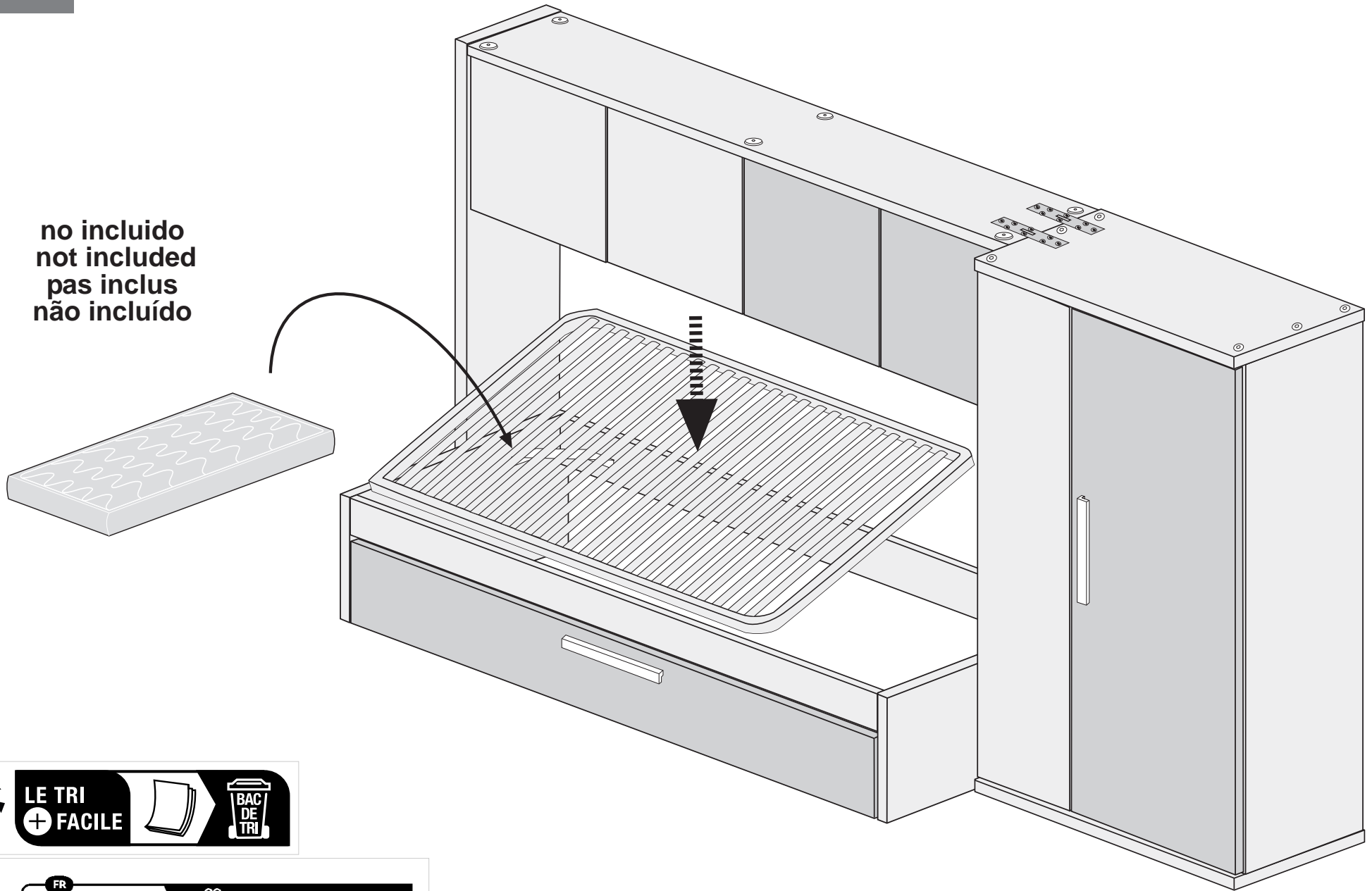

**LE TRI**  
**+ FACILE**



FR

Pensez à  
donner ou recycler.



ou



ou



<https://quefairedemesdechets.fr>